

STRUCTURAL CHEMISTRY OF DONOR-ACCEPTOR INTERACTIONS

HENRY A. BENT

Department of Chemistry, Institute of Technology, University of Minnesota, Minneapolis, Minnesota

Received February 26, 1968

CONTENTS

| | | |
|------|--|-----|
| I. | Introduction..... | 588 |
| II. | Intermolecular Interactions..... | 588 |
| | A. Donor and Acceptor Sites in Different Molecules..... | 588 |
| | 1. Historical Note. Iodine Solutions..... | 588 |
| | 2. Halogen Atoms as Acceptors..... | 589 |
| | 3. Other Donor-Acceptor Systems..... | 596 |
| | B. Donor and Acceptor Sites in the Same Molecule..... | 598 |
| | 1. Inorganic Cyanides..... | 598 |
| | 2. Halogens and Interhalogens..... | 599 |
| | 3. Organic Molecules with Oxygen Atoms as Donors and Halogen Atoms as Acceptors..... | 602 |
| | 4. Molecules with Halogen Atoms as Electron Donors and/or Acceptors..... | 602 |
| | 5. Nearly Linear C-hal...hal-C Interactions..... | 603 |
| | 6. Carbonyl Compounds..... | 604 |
| | C. Relation to the Walden Inversion..... | 605 |
| | D. Comparison with Hydrogen Bonds..... | 606 |
| | 1. Structural Similarities..... | 606 |
| | 2. Spectroscopic Similarities..... | 608 |
| | 3. Other Similarities (Summary)..... | 609 |
| | E. Theoretical Descriptions..... | 609 |
| | F. Incipient Octet Expansions in Inorganic Systems..... | 612 |
| | 1. Elements of Groups V, VI, and VII..... | 612 |
| | 2. Oxides of Groups IV, V, and VI..... | 614 |
| | 3. Selenious Acid, Iodic Acid, and Xenon Trioxide..... | 615 |
| | G. Layer Structures..... | 615 |
| | 1. Metal Halides, Chalcogenides, and Hydroxides..... | 615 |
| | 2. Tetragonal Lead Monoxide and the Inert Pair..... | 616 |
| | H. Solid-State Interactions That May Reflect the Presence of Anticoincident Spin Sets..... | 617 |
| | 1. Introduction. Spatial Correlation of Electrons in Molecules..... | 617 |
| | 2. The Benzene-Halogen Molecule Interaction..... | 618 |
| | 3. The Starch-Iodine Complex and Related Interactions..... | 619 |
| | 4. Solid-State Interactions in Oxygen and Fluorine..... | 619 |
| | 5. Short Hydrogen Bonds..... | 619 |
| | 6. Bridging Oxygen and Fluorine Atoms..... | 621 |
| | 7. The Decaammine- μ -peroxy-dicobalt Cation..... | 624 |
| III. | Intramolecular Donor-Acceptor Interactions..... | 624 |
| | A. Introduction..... | 624 |
| | B. Effects of Multiple Bonds and Electronegative Atoms on Bond Lengths..... | 625 |
| | C. An Anomaly..... | 625 |
| | D. Abnormally Long Bonds..... | 626 |
| | E. The Methyl Halides and Hydridic Hydrogen Atoms..... | 634 |
| | F. Tilted Methyl Groups..... | 635 |
| | G. Theoretical Descriptions..... | 635 |
| | H. Graphic Representation..... | 636 |
| | I. Additional Examples of Intramolecular Interactions of Unshared Electrons..... | 636 |
| | 1. Molecules and Ions with Abnormally Short Bonds..... | 636 |
| | 2. Molecules with Unusual Physical Properties..... | 640 |
| | 3. Hard and Soft Acids and Bases..... | 644 |
| | J. Steric Requirements..... | 645 |
| | 1. Structures of Halo-1,4-dioxanes..... | 645 |
| | 2. Structure of Dimethyl Ether..... | 646 |
| | 3. Structures and Basicities of Cyclic Ethers..... | 646 |
| | 4. Structures of Methyl Formate, Cyclic Anhydrides, and Related Molecules..... | 646 |
| IV. | Summary..... | 647 |

I. INTRODUCTION

"There are . . . Agents in Nature able to make the particles of Bodies stick together by very strong Attractions," wrote Newton in 1718, "And it is the Business of experimental Philosophy to find them out."¹ What these agents are and how they act, within and between molecules, is the subject of this review.

That molecular association is fundamentally an electrical phenomenon was recognized by Sir Oliver Lodge soon after the discovery of the electron. Lodge pictured the agents of molecular attraction as stray "feeler" lines of force that emanate from localized charges in one molecule and terminate on localized charges in other molecules.² In this type of intermolecular linkage, remarked Lodge, a quite gradual change of valency is conceivably possible. Indeed, recent studies have revealed that, in addition to hydrogen bonds, there exist in crystals many molecular connections intermediate in length and strength between van der Waals contacts and normal covalent bonds.³ These intermolecular interactions will be described, interpreted electronically, and related to analogous intramolecular interactions. It will be seen that many short intermolecular interactions (including hydrogen bonds) may be viewed as incipient valence-shell expansions and often as the first stages of bimolecular nucleophilic displacement reactions.

Although the formation of molecular complexes is well known, owing particularly to extensive investigations of molecular weights in solution toward the end of the last century,⁴ relatively little progress has been made in incorporating the structures of these complexes into a general theory of valence. They are, Lewis noted, the outcasts of our present chemical system.⁵

Also, it is well known that the van der Waals radius of an atom is more variable than the corresponding covalent radius^{6,7} and, further, that an atom's van der Waals radius is not entirely independent of direction,⁸ yet very little theoretical attention has been given to the determination of intermolecular interactions at intermediate separations such as occur in the vicinity of the equilibrium separation of neighboring molecules in a crystal.⁹ The angular dependence of intermolecular forces, particularly, is one of the least understood features of our knowledge of the ways in which molecules

interact.¹⁰ It is indeed surprising how little is known about the action, not to say the nature, of intermolecular forces when one considers their importance in a wide variety of problems.¹¹ What is needed, Coulson has said, are new concepts.¹²

The chief conclusion of the present review is that what is needed to understand, if not yet fully to predict, the stereochemistry of intermolecular interactions are new applications of old concepts. The data in the literature through 1967 support the view that in condensed systems molecules may be regarded as having shapes suggested by their chemical structural formulas¹³ and that attractive interactions between them generally involve the sharing, albeit perhaps weakly, of electron pairs.⁵ Striking support for these conclusions has been obtained by Hassel¹⁴⁻¹⁷ and his coworkers in studies of the structures of molecular complexes formed by electron-pair donors and halogen molecules. The best known of these complexes are those between oxygen-containing solvents and molecular iodine.

II. INTERMOLECULAR INTERACTIONS

A. DONOR AND ACCEPTOR SITES IN DIFFERENT MOLECULES

1. Historical Note. Iodine Solutions

It is well known that free iodine dissolved in water, alcohol, and similar electron-pair donor solvents gives brown solutions, while in solvents of lower basicity, such as carbon tetrachloride and benzene, it gives violet and red-violet solutions.¹⁸⁻²¹ These solutions have been widely studied.²²

The solubility of iodine, its heat of solution, and its chemical reactivity are generally greater for solvents that give brown solutions than for solvents that give violet solutions.^{23,24} Further, violet solutions often turn brown on the addition of a solvent such as alcohol, whereas brown solutions often turn violet on heating (and brown again on cooling).¹⁸ And, although the molecular weight of iodine in both types of solvent corresponds to the formula I_2 ,²⁵ the freezing point depres-

(1) I. Newton, "Opticks," 4th ed, Book 3, Part I, G. Bell and Sons' Ltd., London, 1931, Question 31.

(2) O. Lodge, *Nature*, **70**, 176 (1904).

(3) O. Bastiansen and E. W. Lund, *Ann. Rev. Phys. Chem.*, **10**, 31 (1959).

(4) E. N. Lassetre, *Chem. Rev.*, **20**, 259 (1937).

(5) G. N. Lewis, *J. Franklin Inst.*, **226**, 301 (1938).

(6) S. B. Hendricks, *Chem. Rev.*, **7**, 431 (1930).

(7) L. Pauling, "Nature of the Chemical Bond," 3rd ed, Cornell University Press, Ithaca, N. Y., 1960.

(8) D. A. Bekoe and K. N. Trueblood, *Z. Krist.*, **113**, 1 (1960).

(9) J. O. Hirschfelder, C. F. Curtiss, and R. B. Bird, "Molecular Theory of Gases and Liquids," John Wiley and Sons, Inc., New York, N. Y., 1954.

(10) R. G. Gordon, *J. Chem. Phys.*, **40**, 1973 (1964).

(11) J. O. Hirschfelder, *ibid.*, **43**, S199 (1965).

(12) C. A. Coulson, *Rev. Mod. Phys.*, **32**, 170 (1960).

(13) I. Langmuir, *Chem. Rev.*, **6**, 451 (1929).

(14) O. Hassel, *Proc. Chem. Soc. (London)*, 250 (1957).

(15) O. Hassel, *Mol. Phys.*, **1**, 241 (1958).

(16) O. Hassel and C. Rømming, *Quart. Rev. (London)*, **16**, 1 (1962).

(17) O. Hassel in "The Law of Mass Action," Det Norske Videnskaps-Akademi I, Oslo, Norway, 1964, pp 173-183.

(18) A. Lachman, *J. Am. Chem. Soc.*, **25**, 50 (1903).

(19) J. H. Hildebrand and B. L. Glascock, *ibid.*, **31**, 26 (1909).

(20) O. J. Walker, *Trans. Faraday Soc.*, **31**, 1432 (1935).

(21) F. Fairbrother, *J. Chem. Soc.*, 1051 (1948).

(22) J. H. Hildebrand and R. L. Scott, "The Solubility of Non-electrolytes," Reinhold Publishing Corp., New York, N. Y., 1950.

(23) J. Kleinberg and A. W. Davidson, *Chem. Rev.*, **42**, 601 (1948).

(24) K. Hartley and H. A. Skinner, *Trans. Faraday Soc.*, **46**, 621 (1950).

(25) E. Beckman, *Z. Physik. Chem.*, **5**, 76 (1890); **58**, 543 (1907).

sion constant of a violet-giving solvent that contains both iodine and a brown-giving solvent is abnormally small.¹⁹

These facts have led to the assumption that the source of the brown color is a complex between molecular iodine and electron-pair donor solvents. Indeed, in 1863 a substance with the composition NH_3I_2 had been proposed²⁶ and in 1896 it was reported²⁷ that direct addition of trimethylamine to bromine produces pale yellow crystals with the composition $(\text{CH}_3)_3\text{N}\cdot\text{Br}_2$. By analogy with the addition products formed between amines and hydrogen halides, these substances were formulated^{26,28} as $[\text{NH}_3\text{I}]\text{I}$ and $[(\text{CH}_3)_3\text{NBr}]\text{Br}$. Later it was suggested that the two halogen atoms might be equivalent.²⁹ Recent X-ray crystallographic studies have shown that the former suggestion is more nearly correct.

2. Halogen Atoms as Acceptors

a. Oxygen atoms as donors

The first X-ray crystallographic study of a molecular addition compound containing a halogen molecule and an electron-pair donor molecule was Hassel and Hvoslef's determination in 1954 of the structure of the 1:1 complex formed by molecular bromine and 1,4-dioxane.³⁰ The most striking feature of the structure is a short intermolecular interaction between the oxygen atoms of dioxane and the bromine atoms of molecular bromine. The $\text{O}\cdots\text{Br}$ distance in the crystal is only 2.71 Å; the sum of the van der Waals radii of oxygen and bromine is 3.35 Å. Other interatomic distances appear to be normal, with the possible exception of the $\text{Br}-\text{Br}$ distance of 2.31 Å; this is slightly longer than the $\text{Br}-\text{Br}$ distance of 2.28 Å in gaseous bromine. These numbers are given in the fourth column of Table I, after item 3. Observed distances are given above the dotted and solid lines; normal van der Waals and single bond distances are given below the lines, in parentheses.

As indicated in Table I, the oxygen atom of a dioxane molecule and the two bromine atoms of an adjacent bromine molecule lie nearly on a straight line; the $\text{O}\cdots\text{Br}-\text{Br}$ "bond angle" (the angle between the $\text{O}\cdots\text{Br}$ "bond" and the $\text{Br}-\text{Br}$ bond) is approximately 180°. The $\text{C}-\text{O}\cdots\text{Br}$ "bond" angle, by contrast, is approximately tetrahedral. Interestingly, each bromine molecule is involved in *two*, short, $\text{O}\cdots\text{Br}$ interactions, one off each end of the bromine-bromine bond. Similarly, each dioxane molecule is involved in two $\text{O}\cdots\text{Br}$ interactions, one off each equatorial, oxygen-atom lone pair. Formed, thus, are endless chains of alternating dioxane and bromine molecules (Figure 1). The struc-

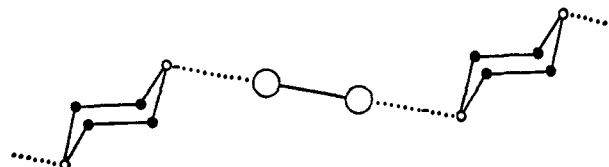

Figure 1.—1:1 molecular complex between bromine and 1,4-dioxane: filled circles, carbon; small open circles, oxygen; large open circles, bromine.

ture may be described as electron-pair donor molecules linked together by linear, halogen molecule bridges.

Linear, halogen molecule bridges are found also in the 1:1 addition compound between acetone and bromine³¹ (Table I, no. 4). This structure was the first example of two halogen molecule bridges starting from a common oxygen atom (Figure 2). The $\text{Br}\cdots\text{O}\cdots\text{Br}$ angle is 110°.

Dioxane also forms addition compounds with oxalyl bromide^{17,32} (Figure 3), oxalyl chloride,^{17,32} and diiodoacetylene.³³ All three compounds contain short oxygen \cdots halogen distances (Table I, no. 6, 2, and 8, respectively). Thus, in addition to bromine, the acceptor atom may be chlorine or iodine; further, the acceptor atom need not be bound to another halogen atom.

No addition compounds with fluorine as the acceptor atom have been reported.

There is reason to believe that the $\text{O}\cdots\text{Br}-\text{Br}$ interaction is energetically comparable to a strong hydrogen bond.³⁴ With methanol, for example, molecular bromine forms a 2:1 addition compound.^{34,35} In this compound each oxygen atom is linked, approximately tetrahedrally, to four atoms: to the carbon atom of its methyl group through an ordinary covalent bond; to two oxygen atoms of adjacent methanol molecules through ordinary hydrogen bonds; and to a bromine atom of an adjacent bromine molecule through a short $\text{O}\cdots\text{Br}$ interaction (Table I, no. 5).

Table I lists several other examples of crystals that contain short interactions between oxygen-containing molecules and halogen-containing molecules.^{17,36} In each case the angle about the halogen acceptor atom, *i.e.*

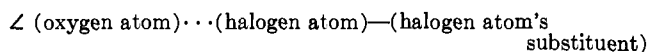

is close to linear, while the angle about the oxygen donor atom, *i.e.*

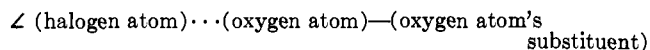

is close to tetrahedral.

(26) F. Guthrie, *J. Chem. Soc.*, 16, 239 (1863).

(27) I. Remsen and J. F. Norris, *Am. Chem. J.*, 18, 90 (1896).

(28) A. Hantzsch, *Ber.*, 38, 2161 (1905).

(29) R. S. Mulliken, *J. Am. Chem. Soc.*, 74, 811 (1952).

(30) O. Hassel and J. Hvoslef, *Acta Chem. Scand.*, 8, 873 (1954).

(31) O. Hassel and K. O. Strømme, *ibid.*, 31, 275 (1959).

(32) E. Damm, O. Hassel, and C. Rømming, *ibid.*, 19, 1159 (1965).

(33) P. Gagnaux and B. P. Susz, *Helv. Chim. Acta*, 43, 948 (1960).

(34) P. Groth and O. Hassel, *Acta Chem. Scand.*, 18, 402 (1964).

(35) P. Groth and O. Hassel, *Mol. Phys.*, 6, 543 (1963).

(36) P. Groth and O. Hassel, *Acta Chem. Scand.*, 19, 1733 (1965).

TABLE I
SHORT INTERMOLECULAR INTERACTIONS INVOLVING HALOGEN ATOMS AS ELECTRON-PAIR ACCEPTORS,
IN TWO-COMPONENT SYSTEMS

| No. | Donor molecule | Acceptor molecule | Interaction ^a | Fig | Ref |
|-----|------------------------|---------------------|---|-----|--------|
| 1 | 1,4-Dioxane | Chlorine | O ······· Cl ——— Cl 2.67 2.02 (3.20) (1.99) | | 17 |
| 2 | 1,4-Dioxane | Oxalyl chloride | O ······· Cl ——— C 3.18 (3.20) (1.72) | | 17, 32 |
| 3 | 1,4-Dioxane | Bromine | O ······· Br ——— Br 2.71 2.31 (3.35) (2.28) | 1 | 30 |
| 4 | Acetone | Bromine | O ······· Br ——— Br 2.82 2.28 (3.35) (2.28) | 2 | 31 |
| 5 | Methanol | Bromine | O ······· Br ——— Br 2.78 2.29 (3.35) (2.28) | | 34, 35 |
| 6 | 1,4-Dioxane | Oxalyl bromide | O ······· Br ——— C (1.89) | 3 | 17, 32 |
| 7 | Cyclohexane-1,4-dione | Diiodoacetylene | O ······· I ——— C 2.93 1.98 (3.55) (1.99) | | 36 |
| 8 | 1,4-Dioxane | Diiodoacetylene | O ······· I ——— C 2.65(?) (3.55) (1.99) | | 33 |
| 9 | Acetonitrile | Bromine | N ······· Br ——— Br 2.82 2.28 (3.45) (2.28) | | 17 |
| 10 | Hexamethylenetetramine | Bromine | N ······· Br ——— Br 2.26 2.4 (3.45) (2.28) | 6 | 40 |
| 11 | Pyrazine | Tetrabromoethylene | N ······· Br ——— C 3.02 1.88 (3.45) (1.89) | 5 | 39 |
| 12 | Trimethylamine | Iodine | N ······· I ——— I 2.27 2.83 (3.65) (2.67) | | 17 |
| 13 | 4-Picoline | Iodine | N ······· I ——— I 2.31 2.83 (3.65) (2.67) | | 43 |
| 14 | Trimethylamine | Iodine monochloride | N ······· I ——— Cl 2.30 2.52 (3.65) (2.30) | 4 | 37 |
| 15 | Pyridine | Iodine monochloride | N ······· I ——— Cl 2.26 2.51 (3.65) (2.30) | | 41 |
| 16 | Quinoline | Iodoform | N ······· I ——— C 3.05 (3.65) (2.13) | | 38 |
| 17 | 1,4-Dithiane | Iodine | S ······· I ——— I 2.87 2.79 (4.00) (2.67) | | 47 |
| 18 | 1,4-Dithiane | Diiodoacetylene | S ······· I ——— C 3.27 (4.00) (1.99) | 8 | 49 |
| 19 | 1,4-Dithiane | Iodoform | S ······· I ——— C 3.32 ~2.10 (4.00) (2.13) | 7 | 48 |

TABLE I (Continued)

| No. | Donor molecule | Acceptor molecule | Interaction ^a | Fig | Ref |
|-----|------------------------|--------------------|---|-----|-----|
| 20 | 1,4-Dithiane | Antimony triiodide | S.....Sb— I (4.35) (2.719) | | 52 |
| 21 | Benzyl sulfide | Iodine | S.....I—I (4.00) (2.82) (2.67) | | 46 |
| 22 | Sulfur, S ₈ | Iodoform | S.....I—C (4.00) (3.50) (2.10) (2.13) | | 50 |
| 23 | Sulfur, S ₈ | Antimony triiodide | S.....I—Sb (4.00) (3.60) (2.747) (2.70) | | 51 |
| 24 | 1,4-Diselenane | Iodine | Se.....I—I (4.15) (2.829) (2.87) (2.66) | | 53 |
| 25 | 1,4-Diselenane | Diiodoacetylene | Se.....I—C (4.15) (3.34) (1.99) | 9 | 49 |
| 26 | 1,4-Diselenane | Tetraiodoethylene | Se.....I—C (4.15) (3.41) (2.12) (2.10) | | 56 |
| 27 | Tetrahydroselenophene | Iodine | Se.....I—I (4.15) (2.762) (2.914) (2.67) | | 54 |

^a Short intermolecular interaction (.....) and lengthened intramolecular interaction (—), in Å (normal distances in parentheses).

b. Nitrogen atoms as donors

Amines, like ethers and ketones, form addition compounds with halogen-containing molecules. Trimethylamine forms, for example, a 1:1 adduct with iodine¹⁷ and iodine monochloride³⁷ (Figure 4). The nitrogen atom of this adduct is tetrahedrally coordinated by three methyl groups and an iodine atom. The coordination about the iodine atom, N···I—hal, is linear. Again, there is an unusually short intermolecular interaction between the electron-pair donor atom, nitrogen, and the halogen atom, iodine. The N···I distances are approximately 2.30 Å (Table I, no. 12, 14), 1.35 Å less than the sum of the nitrogen and iodine atoms' van der Waals radii and only 0.25 Å greater than the sum of their covalent radii. Other interatomic distances are normal, with the notable exception of the I—I and I—Cl distances, which are significantly longer, by approximately 0.2 Å, than the corresponding distances in the gaseous molecules (Table I).

Linear (donor)···(acceptor)—(acceptor substituent) interactions between nitrogen-containing molecules and halogen-containing molecules have been reported for several other systems (Table I). Quinoline and iodoform form a 3:1 adduct (no. 16) that contains discrete (iodoform)(quinoline)₃ complexes;³⁸ each complex is held together by three, linear N···I—C interactions. Pyrazine and tetrabromoethylene form a 1:1 complex (no. 11) that contains endless chains of

alternating pyrazine and tetrabromoethylene molecules;³⁹ each chain is held together by linear N···Br—C interactions (Figure 5).

In linear (donor)···(acceptor)—(acceptor substituent) interactions, the (donor)···(acceptor) interaction generally appears to be stronger (*i.e.*, shorter), and the corresponding (acceptor)—(acceptor substituent) interaction generally appears to be weaker (*i.e.*, longer) when the donor atom is nitrogen than when it is oxygen (Table I). For many amine-halogen molecule adducts, it is, in fact, quite arbitrary, from the viewpoint of interatomic distances, which of the two atomic connections, nitrogen-halogen or halogen-halogen, is labeled intermolecular (.....) and which is labeled intramolecular (—); both connections are only slightly longer than the corresponding normal covalent bond distances. In the limit of a strong nitrogen-halogen interaction, however, the halogen-halogen interaction may be so weakened,⁴⁰ heterolytically that an appropriate formulation of the adduct is a covalent-ionic formulation [N—hal]⁺[hal]⁻, close to that suggested originally.^{26,28} In the presence of additional donor and acceptor molecules, such an adduct might be expected to go on to form linear [N—hal—N]⁺ cations and, perhaps, linear [hal]₃⁻ anions, or (see later) higher polyhalide anions. Indeed, pyridine (py), in contrast to the 1:1 molecular adduct formed with iodine monochloride (Table I, no. 15),⁴¹ forms with molec-

(37) O. Hassel and H. Hope, *Acta Chem. Scand.*, **14**, 391 (1960).

(38) T. Bjorvatten and O. Hassel, *ibid.*, **16**, 249 (1962).

(39) T. Dahl and O. Hassel, *ibid.*, **20**, 2009 (1966).

(40) G. Eia and O. Hassel, *ibid.*, **10**, 139 (1956).

(41) O. Hassel and C. Rømming, *ibid.*, **10**, 696 (1956).

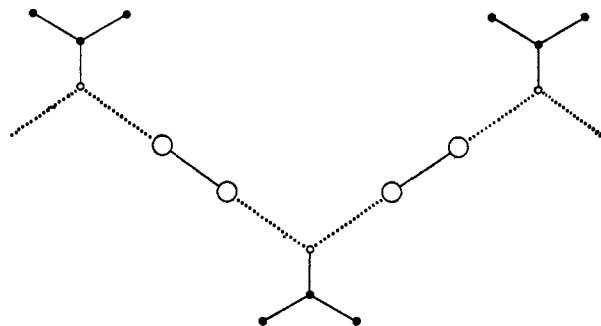

Figure 2.—1:1 molecular complex between bromine and acetone.

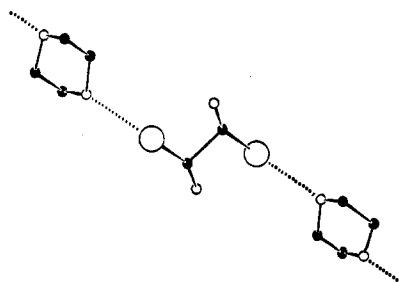

Figure 3.—1:1 molecular complex between oxalyl bromide and 1,4-dioxane.

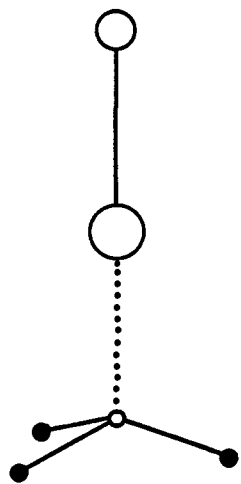

Figure 4.—1:1 molecular complex between iodine monochloride and trimethylamine: filled circles, carbon; small open circle, nitrogen; largest open circle, iodine.

ular iodine a 1:2 ionic adduct that contains linear $[\text{py-I-py}]^+$ cations and I_3^- anions;⁴² the latter are linked together by iodine molecules, much as in I_7^- . Similarly, 4-picoline (pi) forms with iodine, in addition to the water-insoluble, low-melting, 1:1 complex of Table I (no. 13),⁴³ a water-soluble, high-melting, 2:1 complex⁴⁴ that contains no iodine-iodine distance shorter than 3 Å and is probably best formulated as $[\text{pi-I-pi}]^+\text{I}^-$.

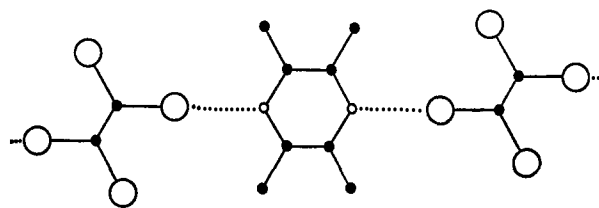

Figure 5.—1:1 molecular complex between tetrabromoethylene and pyrazine.

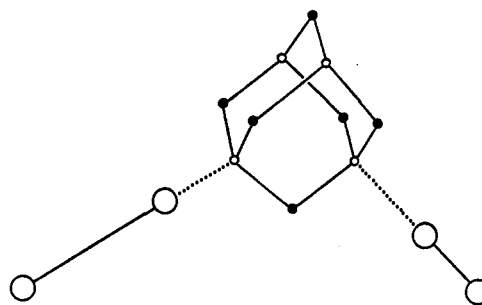

Figure 6.—2:1 molecular complex between bromine and hexamethylenetetramine.

These data show that donor molecules are capable of producing anionic-type properties in acceptor molecules, the more so the stronger the donor. This action limits the number of effective acceptor sites in an acceptor molecule. For such a strong donor atom as nitrogen, for example (the heat of formation of the trimethylamine-iodine adduct, from its constituent molecules, in *n*-heptane, at 25°, is -12 kcal/mole⁴⁵), the second halogen atom in an $\text{N}\cdots\text{hal}-\text{hal}$ interaction evidently is too anionic to interact effectively with a donor molecule. To date no halogen-molecule bridges between tetrahedrally hybridized nitrogen atoms have been reported. Hexamethylenetetramine and bromine form the 1:2 adduct expected for such a structure, but the adduct is composed of discrete (HMTA)(Br₂)₂ complexes^{14,40} (Figure 6).

c. Sulfur atoms as donors

In 1960 it was found^{46,47} that organic sulfur compounds could form molecular addition compounds (Table I, no. 17, 21) in the same way as do amines, ethers, and ketones.

In the 1:1 dithiane-iodoform adduct,⁴⁸ two iodine atoms of each iodoform molecule form with sulfur atoms in neighboring dithiane molecules linear $\text{S}\cdots\text{I}-\text{C}$ interactions that link the molecules together into endless chains (Figure 7). Linear $\text{S}\cdots\text{I}-\text{C}$ interactions are responsible, also, for the formation of endless chains in the 1:1 adduct of dithiane and diiodoacetylene;⁴⁹

(45) S. Nagakura, *J. Am. Chem. Soc.*, **80**, 520 (1958).

(46) C. Rømming, *Acta Chem. Scand.*, **14**, 2145 (1960).

(47) G. Y. Chao and J. D. McCullough, *Acta Cryst.*, **13**, 727 (1960).

(48) T. Bjorvatten and O. Hassel, *Acta Chem. Scand.*, **15**, 1429 (1961).

(49) O. Holmesland and C. Rømming, *ibid.*, **20**, 2601 (1966).

(42) O. Hassel and H. Hope, *Acta Chem. Scand.*, **15**, 407 (1961).

(43) O. Hassel, C. Rømming, and T. Tufte, *ibid.*, **15**, 967 (1961).

(44) D. L. Glusker and A. Miller, *J. Chem. Phys.*, **26**, 331 (1957).

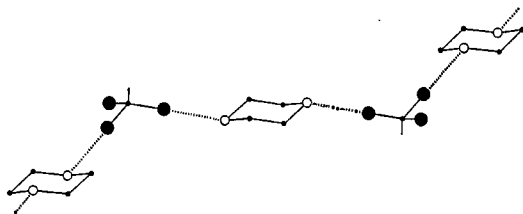

Figure 7.—1:1 molecular complex between iodoform and 1,4-dithiane: small filled circles, carbon; large filled circles, iodine; open circles, sulfur.

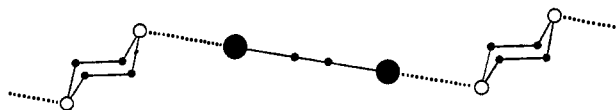

Figure 8.—1:1 molecular complex between diiodoacetylene and 1,4-dithiane.

each iodine atom of a diiodoacetylene molecule is involved in a short $S \cdots I$ interaction with an equatorial lone pair of a neighboring dithiane ring (Figure 8).

In the 1:3 addition compound $CHI_3 \cdot 3S_8$, each iodine atom is connected to a sulfur atom of a particular S_8 ring, off an equatorial position.⁵⁰ Isomorphous crystals with the composition $RI_3 \cdot 3S_8$ are formed⁵⁰ for R equal to CH, P, As, and Sb.⁵¹ In the 2:1 addition compound between antimony triiodide and 1,4-dithiane, short intermolecular interactions are formed between sulfur and antimony atoms.⁵²

d. Selenium atoms as donors

Diselenane, like dithiane, forms molecular addition compounds with iodine-containing molecules (Table I). The selenium-iodine interactions seem generally to occur through the axial rather than the equatorial ring positions, however^{49, 53} (Figure 9).

The lengths of bonds connecting group VI atoms with I_2 in addition compounds have been discussed by Hassel.⁵⁴ A comparison of the distances $S \cdots I$ and $Se \cdots I$ together with the corresponding $I-I$ distances (Table I, no. 17 and 24) suggests that the selenium-iodine interaction is stronger than the sulfur-iodine interaction.⁵⁵ Also, it may be inferred that, toward diselenane, iodine is a better acceptor than diiodoacetylene, which is a better acceptor than tetraiodoethylene,⁵⁵ which in turn is regarded as a better acceptor than aliphatic iodides.⁴⁹

The selenium-iodine interaction is particularly strong in the adduct formed by tetrahydroselenophene and

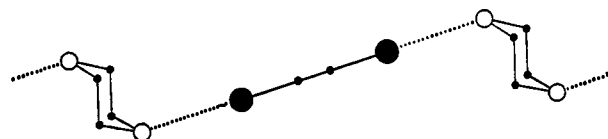

Figure 9.—1:1 molecular complex between diiodoacetylene and 1,4-diselenane.

iodine⁵⁶ (Table I, no. 27); the $Se \cdots I$ distance is the shortest, and the $I-I$ distance the longest, of those listed in Table I. For this adduct the covalent-ionic formulation $[>Se-I]^+[I]^-$ is especially suggestive, for it would appear from interatomic distances that the outer iodine atom, I' , of the interaction $Se \cdots I-I'$ has acquired significant donor properties. It is only 3.64 Å from the selenium atom of an adjacent molecule, with which it forms an angle $I' \cdots Se \cdots I$ of 167° . The structure, Hope and McCullough note,⁵⁶ is tending toward the axial $X-Se-X$ bonding found in R_2SeBr_2 and R_2SeCl_2 compounds.

No structures have been reported for molecular adducts between compounds of sulfur or selenium and molecular chlorine or bromine. Nor have structures been reported of molecular adducts between the halogens and tellurium compounds.

The compound di(*p*-chlorodiphenyl)tellurium diiodide, $(ClC_6H_4)_2TeI_2$, is interesting in this regard. It has axial $I-Te-I$ bonds.⁵⁷ There are, however, tendencies toward molecular complex type bonding:⁵⁸ one $Te-I$ bond is significantly longer than the other; both $Te-I$ bonds are longer than expected for axial type bonding; and the intermolecular $I \cdots I$ packing distance in the line of the $Te-I$ bonds is only 3.85 Å, considerably less than the sum of the van der Waals radii, 4.30 Å.

Thus, by the method of chemical substitution,⁵⁸ it is possible to move in gradual steps from a well-defined molecular adduct, such as the adduct between dithiane and iodine, where the iodine-iodine interaction is relatively strong ($I-I$ distance 2.79 Å; in the vapor 2.67 Å) and no chalcogen-iodine axial-type bonding exists, through an intermediate stage, represented, for example, by the tetrahydroselenophene-iodine adduct, where the iodine-iodine interaction is relatively weak ($I-I$ distance, 2.91 Å) and some axial-type bonding exists, to a genuine chemical compound, such as di-*p*-chlorophenyltellurium iodide, where the iodine-iodine interaction is very weak ($I-I$ distance, 3.85 Å) and relatively strong axial-type bonding exists. In formation of the latter compound from $(ClC_6H_4)_2Te$ and I_2 , the tellurium atoms and iodine molecules behave amphotericly: they act both as donors and acceptors of electrons.

(50) T. Bjorvatten, *Acta Chem. Scand.*, **16**, 749 (1962).

(51) T. Bjorvatten, O. Hassel, and A. Lindheim, *ibid.*, **17**, 689 (1963).

(52) T. Bjorvatten, *ibid.*, **20**, 1863 (1966).

(53) G. Y. Chao and J. D. McCullough, *Acta Cryst.*, **14**, 940 (1961).

(54) O. Hassel, *Acta Chem. Scand.*, **19**, 2259 (1965).

(55) T. Dahl and O. Hassel, *ibid.*, **19**, 2000 (1965).

(56) H. Hope and J. D. McCullough, *Acta Cryst.*, **17**, 712 (1964).

(57) G. Y. Chao and J. D. McCullough, *ibid.*, **15**, 887 (1962).

(58) V. M. Goldschmidt, *Trans. Faraday Soc.*, **25**, 253 (1929).

e. Relative donor and acceptor strengths

The previous discussion introduces the possibility of setting up a scale of the relative strengths of molecules as electron-pair donors and acceptors, based upon interatomic distances in molecular addition compounds. Such a scale will not necessarily be identical with (though it would be surprising if it differed greatly from) scales of donor and acceptor strengths based upon thermodynamic and spectroscopic measurements.

In setting up the present scale, it is assumed that a relatively strong donor-acceptor interaction produces (i) a relatively short distance between the donor and acceptor atoms, compared with the sum of the corresponding van der Waals radii, and (ii) a relatively long distance between the acceptor atom and its substituent(s), compared with the corresponding distance in the uncomplexed acceptor molecule. Listed in Table II are the relative strengths, as electron-pair donors, determined from the data in Table I, of several amines and ketones and dioxane, dithiane, diselenane, and molecular sulfur, and the relative strengths, as electron-pair acceptors, of chlorine, bromine, iodine, iodine monochloride, tetrabromo- and tetraiodoethylene, diiodoacetylene, and iodoform.

Inspection of Table II yields these conclusions. The order of donor strength toward chemically combined halogen atoms is, generally, amines > selenides > sulfides. Donor strength is affected by the state of

TABLE II

RELATIVE DONOR AND ACCEPTOR STRENGTHS DETERMINED FROM INTERATOMIC DISTANCES IN ADDITION COMPOUNDS INVOLVING HALOGEN ATOMS AS ELECTRON-PAIR ACCEPTORS

Relative Donor Strengths

1. Toward bromine
 - a. Dioxane > acetone
 - b. Hexamethylenetetramine > acetonitrile
 - c. Amines > ethers
 2. Toward iodine
 - a. Tetrahydro-selenophene > diselenane
 - b. Benzyl sulfide > dithiane
 - c. Picoline \approx trimethylamine
 3. Toward iodine monochloride
 - Pyridine \approx trimethylamine
 4. Toward diiodoacetylene
 - Dioxane > cyclohexane-1,4-dione
- Relative Acceptor Strengths
5. Toward dioxane
 - a. Bromine > chlorine
 - b. Chlorine \gg oxalyl chloride
 6. Toward dithiane
 - Iodine \gg diiodoacetylene > iodoform
 7. Toward diselenane
 - Iodine \gg diiodoacetylene > tetraiodoethylene > iodoform
 8. Toward amines
 - a. Iodine \approx iodine monochloride \gg iodoform
 - b. Bromine \gg tetrabromoethylene
 - c. Iodine > bromine
 - d. Bromine > iodoform > tetrabromoethylene
 9. Toward molecular sulfur
 - Iodoform > antimony triiodide

hybridization of the donor atom. An oxygen atom hybridized sp^3 (dioxane) is a better electron-pair donor than an oxygen atom hybridized sp^2 (acetone, cyclohexane-1,4-dione), *i.e.*, with regard to the donor strength of oxygen atoms (no. 1a and 4), $O(sp^3) > O(sp^2)$. Similarly, with regard to the donor strength of nitrogen atoms (no. 2c, 3, and 1b), $N(sp^3) \approx N(sp^2) \gg N(sp)$.

The order of acceptor strength of halogen molecules toward amines, ethers, ketones, sulfides, and selenides is, for the systems listed in Tables I and II, $I_2 > Br_2 > Cl_2$. The strength of a halogen atom as an electron-pair acceptor is affected by the chemical nature of the atom to which it is attached. An iodine, bromine, or chlorine atom attached to a similar atom is a better electron-pair acceptor than one attached to a carbon atom (no. 5b, 6, and 8b). Further, the state of hybridization of the carbon atom is important (no. 6, and 7). For the systems listed in Tables I and II, the order of acceptor strength is (hal = halogen) $hal-hal > hal-C(sp) > hal-C(sp^2) > hal-C(sp^3)$.

To summarize, an intermolecular interaction, $D \cdots A-S$, between an electron-pair donor molecule D and an electron-pair acceptor atom A, here a halogen atom, with attached substituent S, generally becomes stronger (i) as the strength of the donor molecule D as a Brønsted base increases (the selenides are exceptions), (ii) as the ability of the acceptor atom A to expand its valence-shell octet increases, and (iii) as the strengths of the substituent S as a Brønsted base decreases. For intermolecular interactions that involve halogen atoms as electron-pair acceptors (as for intermolecular interactions that involve hydrogen atoms as electron-pair acceptors ($A = \text{hydrogen}$)), the better the donor molecule D is as an entering group and the better the acceptor atom A is as an electron-pair acceptor, and the better the substituent S is as a leaving group, the stronger is the intermolecular interaction.

f. Halide ions as donors. Polyhalogen complexes

Although donor strength generally decreases in moving from left to right in the periodic table, halogen atoms, particularly negatively charged halogen atoms, are capable of forming donor-acceptor bonds with halogen molecules. Iodide ions, for example, significantly increase the solubility of molecular iodine in water, owing to the formation of triiodide ions, I_3^- . Many other trihalide ions are known.⁵⁹ In the crystalline state they are linear, or nearly so.

With the cations NH_4^+ and Cs^+ the triiodide ion is asymmetrical^{60,61} (Figure 10a). This structure may

(59) E. E. Havinga and E. H. Wiebenga, *Rec. Trav. Chim.*, **78**, 724 (1959).

(60) R. C. L. Mooney, *Z. Krist.*, **90**, 143 (1935).

(61) H. A. Tasman and K. H. Boswijk, *Acta Cryst.*, **8**, 59 (1955).

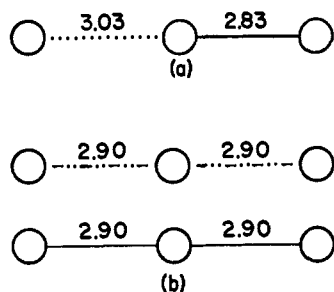

Figure 10.—(a) Asymmetrical triiodide ion in ammonium and cesium triiodide. (b) Symmetrical triiodide ion in tetraphenylarsonium triiodide.

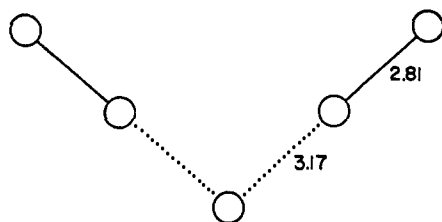

Figure 11.—The planar I_5^- ion, $I_2 \cdot I^- \cdot I_2$.

be viewed as an example of a linear donor-acceptor interaction between an anionic donor, I^- , and a neutral acceptor molecule, I_2 . The interatomic distances designated intermolecular, \cdots , and intramolecular, $-$, are not very different, however, and with the larger cation $(C_6H_5)_4As^+$, the distances are equal⁶² (Figure 10b). They may be represented as strong intermolecular interactions (Figure 10b, top line) or, alternatively, as weak intramolecular interactions (Figure 10b, bottom line).

In the symmetrical I_3^- ion, one sees illustrated, again, an element or arbitrariness, from the structural point of view, in the terms "intermolecular" and "intramolecular," when applied to interactions in condensed systems, where it is not always possible, on the basis of interatomic distances, to define accurately the meaning of the word "molecule."

The interaction of an iodide ion with an iodine molecule does not exhaust the donor properties of the iodide ion. It can coordinate yet a second iodine molecule, forming thereby a planar, V-shaped, pentaiodide ion,^{63,64} I_5^- (Figure 11). Each arm of I_5^- is similar⁶³ to an unsymmetrical triiodide ion (Figure 10a). The "valence" angle $I \cdots I \cdots I$ is normal for a "divalent" atom that has in its valence shell eight electrons. The ion may be formulated as $I(I_2)_2^-$ and described as an iodide ion to which two iodine molecules are attached⁶³ through linear donor-acceptor interactions.⁶⁵

(62) R. C. L. M. Slater, *Acta Cryst.*, **12**, 187 (1959).
 (63) R. J. Hach and R. E. Rundle, *J. Am. Chem. Soc.*, **73**, 4821 (1951).
 (64) J. Broekema, E. E. Havinga, and E. H. Wiebenga, *Acta Cryst.*, **10**, 596 (1957).
 (65) H. A. Bent, *J. Chem. Educ.*, **40**, 523 (1963).

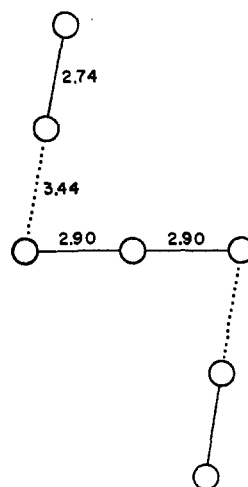

Figure 12.—The planar I_7^- ion, $I_2 \cdot I_3^- \cdot I_2$.

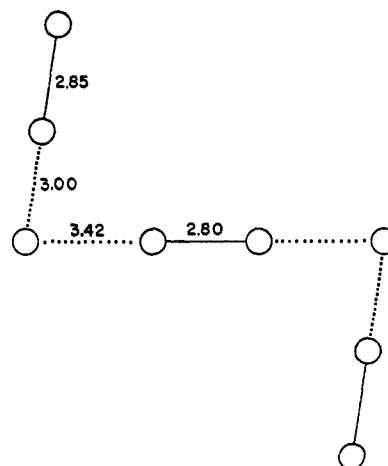

Figure 13.—The planar I_3^{2-} ion, $I_3^- \cdot I_2 \cdot I_3^-$.

The donor properties of the triiodide ion are further illustrated by the structures of $(C_2H_5)_4NI_7$ and CsI_4 . The former compounds may be said, somewhat arbitrarily,⁶⁶ to contain the anion I_7^- . This ion may be formulated as $I_3(I_2)_2^-$ and described as a symmetrical triiodide ion to which are attached two iodine molecules⁶⁷ (Figure 12). The compound CsI_4 is diamagnetic and is better written Cs_2I_3 . It contains the ion I_3^{2-} . This ion may be formulated as $I_2(I_3)_2^{2-}$ and described as an iodine molecule to which are attached two asymmetrical triiodide ions⁶⁸ (Figure 13). (The distinction between symmetrical and asymmetrical triiodide ions may not be significant, so far as the ion itself is concerned. The observed asymmetry of I_3^- in crystals may be produced entirely by neighboring cations.)

(66) R. E. Rundle, *Survey Progr. Chem.*, **1**, 81 (1963).
 (67) E. E. Havinga and E. H. Wiebenga, *Acta Cryst.*, **11**, 733 (1958).
 (68) E. E. Havinga, K. H. Boswijk, and E. H. Wiebenga, *ibid.*, **7**, 487 (1954).

It may be noted, without explanation, that, in both $(C_2H_5)_4NI_7$ and Cs_2I_8 , the triiodide ion-iodine molecule interactions, $I(\text{of } I_3^-) \cdots I-I$, are relatively weak (Figures 12 and 13), the $I \cdots I$ distances are relatively long (3.44 and 3.42 Å), and the $I-I$ distances are relatively short (2.74 and 2.80 Å). Also, while the "valence" angles at the acceptor atoms are normal ($\sim 180^\circ$), the corresponding angles at the donor atoms (80.5 and 81°) are remarkably small.

3. Other Donor-Acceptor Systems

a. Oxygen atoms as donors. Lindqvist's review

Many other atoms, in addition to halogen atoms, act as acceptors of chemically bound, unshared electrons. Donor-acceptor interactions that involve halogen atoms are, in fact, generally speaking, relatively weak. Molecular adducts produced by stronger interactions, in inorganic systems, from oxygen-containing donor molecules, have recently been reviewed by Lindqvist.⁶⁹

In the donor-acceptor interactions considered by Lindqvist, the atom attached to the donor atom, oxygen, is an atom of intermediate electronegativity from groups V or VI, either nitrogen (in amine oxides, nitro compounds, and nitroso and nitrosyl compounds), phosphorus (in phosphine oxides, esters of phosphoric acid, and phosphoryl halides), arsenic (in arsine oxides), sulfur (in sulfoxides, esters of sulfurous and sulfuric acid, sulfones, and thionyl and sulfuryl halides), or selenium (in selenium oxides, esters of selenious acid, and selenium oxide halides). The substituents attached to the acceptor atoms are generally halogen atoms, usually chlorine or bromine. The acceptor atom itself evidently may be almost any atom in the periodic table, provided its core is neither very large nor very small. No adducts involving acceptor atoms that have core radii greater than 1.0 Å (potassium, rubidium, cesium, strontium, and barium) or less than 0.2 Å (carbon, nitrogen, oxygen, and fluorine) are cited by Lindqvist.

The molecular adduct $SbCl_5 \cdot POCl_3$ ⁶⁹ (Figure 14) is representative of many that are formed by oxo compounds in inorganic systems. Typically, formation of these relatively stable inorganic adducts produces an increase in coordination number, not only of the donor atom, oxygen, as expected, but also of the acceptor atom. In $SbCl_5 \cdot POCl_3$, for example, the bond angles about the antimony atom are all close to 90° (Figure 14), 10° less than the average bond angle in $SbCl_5$. Also, the antimony-oxygen internuclear distance is only 2.17 Å, 1.4 Å less than the sum of the corresponding van der Waals radii. The average antimony-chlorine distance, however, is essentially unchanged.

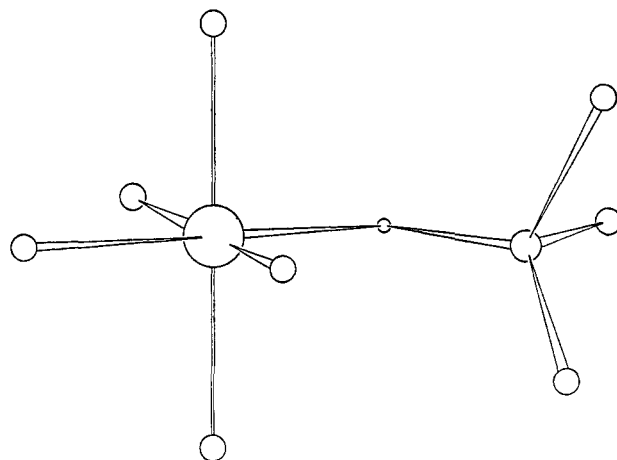

Figure 14.—1:1 molecular adduct $SbCl_5 \cdot POCl_3$ (after Lindqvist⁶⁹).

The antimony-oxygen distance in $SbCl_5 \cdot POCl_3$, though short, is not as short as the length calculated⁷⁰ for an antimony-oxygen single bond (Table III, bottom line). By its length, and strength (determined from thermochemical studies⁶⁹), the Sb-O interaction in $SbCl_5 \cdot POCl_3$ must be classified as something between a van der Waals contact and a normal covalent bond. By contrast, the P-O distance in $SbCl_5 \cdot POCl_3$ is noticeably shorter than the length calculated for a P-O single bond (Table III, third line). It is possibly significant in this regard, as will be discussed later, that the angle Sb-O-P is 145° , much larger than the approximately tetrahedral angle at oxygen in, for example, the molecules H_2O , $(CH_3)_2O$, and F_2O .

TABLE III
OBSERVED AND CALCULATED INTERNUCLEAR DISTANCES FOR THE
MOLECULAR ADDUCT $SbCl_5 \cdot POCl_3$ (FIGURE 14)

| Bond | Obsd length, Å | Calcd length, Å ⁷⁰ | Difference, obsd - calcd |
|-------|----------------|-------------------------------|-----------------------------|
| P-Cl | 1.95 | 2.01 | -0.06 |
| Sb-Cl | 2.33 | 2.29 | +0.04 |
| P-O | 1.47 | 1.71 | -0.24 |
| Sb-O | 2.17 | 1.99 | +0.18 |

Large valence angles at oxygen atoms have been observed in a number of inorganic adducts of oxo compounds⁶⁹ (Table IV). The magnitude of the valence angle at oxygen depends mainly upon the nature of the donor molecule, *i.e.*, upon the nature of the substituent to which the oxygen atom is attached most firmly. In every case, the oxygen atom's firmest attachment is to an atom in the donor molecule. In every case, also, the corresponding bond length is significantly less than that calculated for a single bond (Table IV, third and fourth columns). In general, the larger the difference between the observed and calculated bond lengths (Table IV, last column), the larger is the

(69) I. Lindqvist, "Inorganic Adduct Molecules of Oxo-compounds," Academic Press Inc., New York, N. Y., 1963.

(70) H. A. Bent, *J. Chem. Educ.*, 42, 348 (1965).

TABLE IV
BOND ANGLES AT OXYGEN AND OBSERVED AND CALCULATED INTERNUCLEAR DISTANCES FOR
SOME INORGANIC ADDUCT MOLECULES OF OXO COMPOUNDS

| No. | Adduct | Bond angle at O, ⁶⁹ deg | Obsd internuclear distance to O in donor, Å ⁶⁹ | Calcd distance for single bond to O in donor, Å ⁷⁰ | Diff, obsd - calcd distances, Å |
|-----|---|------------------------------------|---|---|---------------------------------|
| 1 | (TiCl ₄ ·POCl ₃) ₂ | 151.8 | 1.44 | 1.71 | -0.27 |
| 2 | NbCl ₅ ·POCl ₃ | 148.8 | 1.45 | 1.71 | -0.26 |
| 3 | SnCl ₄ ·2POCl ₃ | 144.5, 150.7 | 1.41, 1.49 | 1.71 | -0.30, -0.22 |
| 4 | SbCl ₅ ·(CH ₃) ₂ PO | 144.9 | 1.56 | 1.71 | -0.15 |
| 5 | SbCl ₅ ·POCl ₃ | 145 | 1.47 | 1.71 | -0.24 |
| 6 | SbCl ₅ ·2(C ₆ H ₅) ₂ AsO | 137.2, 140.9 | 1.68, 1.63 | 1.84 | -0.16, -0.21 |
| 7 | SbCl ₅ ·(CH ₃) ₂ SO ₂ | 138.7 | 1.53 | 1.66 | -0.13 |
| 8 | HgCl ₂ ·2(C ₆ H ₅) ₂ AsO | 134.4, 136.7 | 1.69 | 1.84 | -0.15 |
| 9 | SnCl ₄ ·2(CH ₃) ₂ SO | 121, 126 | 1.51, 1.54 | 1.66 | -0.15, -0.12 |
| 10 | SbCl ₅ ·SeOCl ₂ | 120.9, 121.7 | 1.63, 1.72 | 1.79 | -0.16, -0.07 |
| 11 | SnCl ₄ ·2SeOCl ₂ | 121.5 | 1.73 | 1.79 | -0.06 |
| 12 | BF ₃ ·(CH ₃) ₂ SO | 119.2 | 1.52 | 1.66 | -0.14 |
| 13 | SbCl ₅ ·(C ₆ H ₅) ₂ SO | 117 | 1.53 | 1.66 | -0.13 |

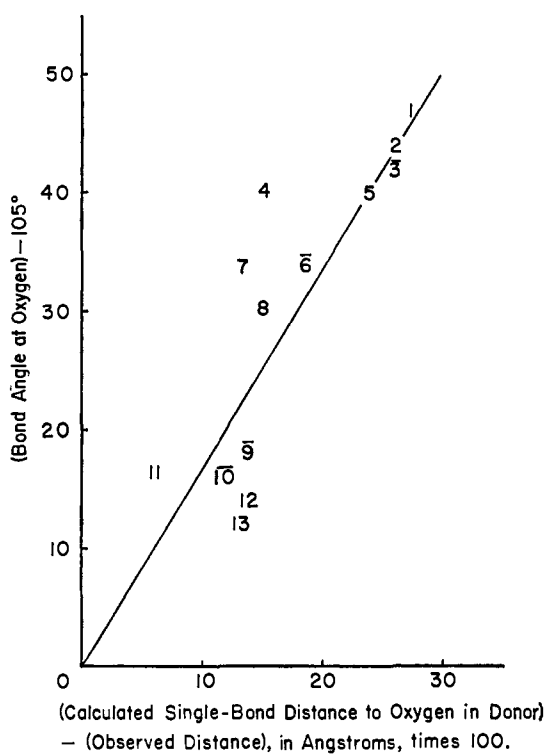

Figure 15.—Plot of the bond angle at oxygen (less 105°) in inorganic adduct molecules of oxo compounds against the difference between the calculated single-bond distance to oxygen in the donor molecule and the observed distance: data from Table IV.

valence angle at the oxygen atom (Figure 15) and, very broadly speaking, the weaker is the donor-acceptor bond, as determined, for example, by the heat of the reaction $\text{SbCl}_5(\text{sol}) + \text{donor} = \text{SbCl}_5 \cdot \text{donor}$. From the value of ΔH for this reaction, the order of donor strength toward SbCl_5 is found to be⁶⁹ $(\text{CH}_3)_2\text{SO} > (\text{CH}_3)_2\text{SO}_2 > \text{POCl}_3$. This order is the reverse of the order found for the bond angle at oxygen in the adducts with SbCl_5 : the angle at oxygen is largest for the POCl_3 adduct and smallest for the sulfoxide adduct (Table IV, no. 5, 7, and 13).

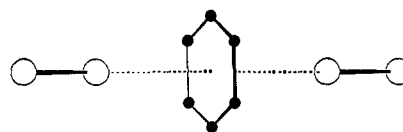

Figure 16.—1:1 molecular complex between bromine and benzene, in the solid phase.

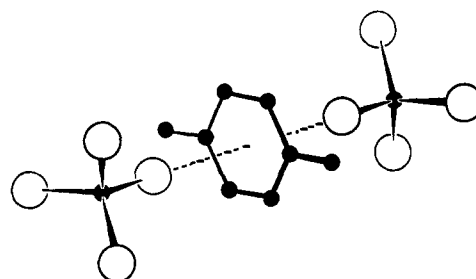

Figure 17.—1:1 molecular complex between carbon tetrabromide and *p*-xylene.

b. Aromatic molecules as donors. Other reviews

Aromatic molecules form weak donor-acceptor adducts with molecules such as bromine⁷¹ and carbon tetrabromide⁷² (Figures 16 and 17). The structures of these adducts are still a theoretical puzzle.⁷³ Possible reasons as to why the halogen-halogen or carbon-halogen bonds in these 1:1 complexes are perpendicular to the planes of the aromatic rings will be discussed later (section II.H.2). Some adducts of aromatic molecules exhibit significant semiconductivity⁷⁴ and paramagnetism^{75,76} and have been judged, from spec-

(71) O. Hassel and K. O. Strømme, *Acta Chem. Scand.*, **12**, 1146 (1958).

(72) F. J. Strieter and D. H. Templeton, *J. Chem. Phys.*, **37**, 116 (1962).

(73) R. S. Mulliken and W. B. Person, *Ann. Rev. Phys. Chem.*, **13**, 107 (1962).

(74) H. Akamatu, H. Inokuchi, and Y. Matsunaga, *Bull. Chem. Soc. Japan*, **29**, 213 (1956).

(75) Y. Matsunaga and C. A. McDowell, *Nature*, **185**, 916 (1960).

(76) D. Bijl, H. Kainer, and A. C. Rose-Innes, *J. Chem. Phys.*, **30**, 765 (1959).

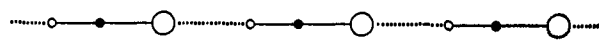

Figure 18.—Structure of the crystalline halogen cyanides ClCN, BrCN, and ICN: small filled circles, carbon; small open circles, nitrogen; large open circles, halogen.

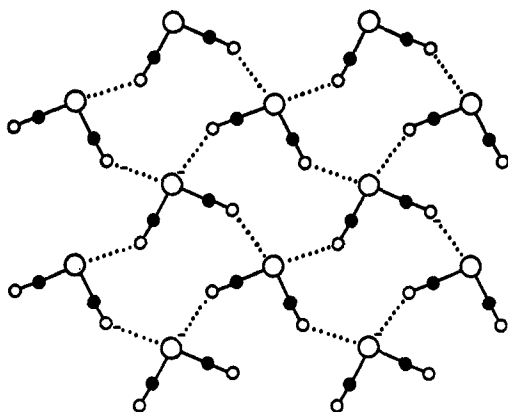

Figure 19.—Nearly planar molecular layers in crystalline sulfur dicyanide: small filled circles, carbon; small open circles, nitrogen; large open circles, sulfur.

troscopic studies,⁷⁷⁻⁷⁹ to have pronounced ionic character in their ground states. General reviews on molecular complexes, particularly on complexes of aromatic molecules, have been given by Andrews,⁸⁰ Andrews and Kieffer,⁸¹ and Briegleb.⁸² The early review by Pfeiffer⁸³ cites numerous molecular complexes whose structures have not yet been determined.

B. DONOR AND ACCEPTOR SITES IN THE SAME MOLECULE

1. Inorganic Cyanides

The cyanides of elements of intermediate atomic weights from groups IV, V, VI, and VII of the periodic table form, as a rule, comparatively high-melting molecular crystals that contain relatively short interactions between the nitrogen atom of a cyanide group in one molecule and a coordinatively unsaturated acceptor atom in an adjacent molecule. Well known in this regard are the cyanides of group VII, ClCN,⁸⁴ BrCN,⁸⁵ and ICN.⁸⁶ In the solid state each molecule participates in two, short intermolecular interactions, which produce infinite, linear chains (Figure 18).

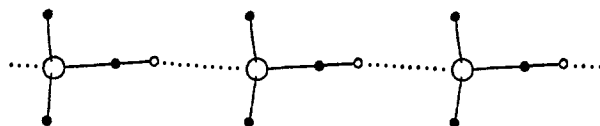

Figure 20.—Molecular chains in crystalline $(\text{CH}_3)_3\text{AsCN}$.

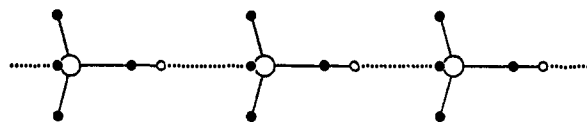

Figure 21.—Molecular chains in crystalline $(\text{CH}_3)_3\text{GeCN}$.

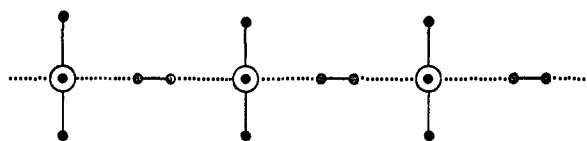

Figure 22.—Molecular chains in crystalline $(\text{CH}_3)_3\text{SnCN}$: small filled circles, carbon; large circles, Sn; small, stippled spheres, carbon or nitrogen of bridging CN groups.

In the dicyanides of sulfur⁸⁷ and selenium,⁸⁸ each molecule participates in four, short, intermolecular interactions, which produce infinite, nearly planar sheets (Figure 19). Short intermolecular interactions between cyanide groups and chalcogens are found also in $\text{S}(\text{SCN})_2$,⁸⁹ $\text{Se}(\text{SCN})_2$,⁹⁰ and $\text{Se}(\text{SeCN})_2$.⁹¹

In $\text{P}(\text{CN})_3$ all three CN groups participate in short intermolecular interactions; the $\text{N}\cdots\text{P}-\text{C}$ angles, however, are far from linear.⁹² In $\text{As}(\text{CN})_3$ ⁹³ and $\text{CH}_3\text{As}(\text{CN})_2$,⁹⁴ as in $(\text{CH}_3)_2\text{AsCN}$,⁹⁵ only one group per molecule participates in an obviously short intermolecular interaction (Figure 20).

In $(\text{CH}_3)_3\text{GeCN}$ the CN groups point toward Ge atoms in adjacent molecules in the manner expected for short intermolecular interactions⁹⁶ (Figure 21). The $\text{N}\cdots\text{Ge}$ distance, however, is only slightly less than that expected for a van der Waals contact. In the corresponding tin compound, $(\text{CH}_3)_3\text{SnCN}$, the intermolecular interactions are much stronger;⁹⁷ they are so strong, in fact, that the integrity of the original molecules is lost. The crystalline compound may be described as containing planar trimethyltin cations⁹⁸ solvated by bridging cyanide groups (Figure 22).

(77) P. L. Kronick, H. Scott, and M. M. Labes, *J. Chem. Phys.*, **40**, 890 (1964).

(78) Y. Matsunaga, *ibid.*, **41**, 1609 (1964).

(79) B. G. Anex and E. B. Hill, Jr., *J. Am. Chem. Soc.*, **88**, 3648 (1966).

(80) L. J. Andrews, *Chem. Rev.*, **54**, 713 (1954).

(81) L. J. Andrews and R. M. Kieffer, "Molecular Complexes in Organic Chemistry," Holden-Day, Inc., San Francisco, Calif., 1964.

(82) G. Briegleb, "Elektronen-Donator-Acceptor-Komplexe," Springer-Verlag, Berlin, 1961.

(83) P. Pfeiffer, "Organische Molekulverbindungen," 2nd ed, F. Enke, Stuttgart, Germany, 1927.

(84) R. B. Heiart and G. B. Carpenter, *Acta Cryst.*, **9**, 889 (1956).

(85) S. Geller and A. L. Schawlow, *J. Chem. Phys.*, **23**, 779 (1955).

(86) J. A. A. Ketelaar and J. W. Zwartsenberg, *Rec. Trav. Chim.*, **58**, 448 (1939).

(87) K. Emerson, *Acta Cryst.*, **21**, 970 (1966).

(88) A. C. Hazell, *ibid.*, **16**, 843 (1963).

(89) F. Feher and K. H. Linke, *Z. Anorg. Allgem. Chem.*, **327**, 151 (1964).

(90) S. M. Ohlberg and P. A. Vaughn, *J. Am. Chem. Soc.*, **76**, 2649 (1954).

(91) O. Aksnes and O. Foss, *Acta Chem. Scand.*, **8**, 1787 (1954).

(92) K. Emerson and D. Britton, *Acta Cryst.*, **17**, 1134 (1964).

(93) K. Emerson and D. Britton, *ibid.*, **16**, 113 (1963).

(94) E. O. Schlemper and D. Britton, *ibid.*, **20**, 777 (1966).

(95) N. Camerinan and J. Trotter, *ibid.*, **16**, 922 (1963).

(96) E. O. Schlemper and D. Britton, *Inorg. Chem.*, **5**, 511 (1966).

(97) E. O. Schlemper and D. Britton, *ibid.*, **5**, 507 (1966).

(98) R. S. Tobias, *Organometal. Chem. Rev.*, **1**, 93 (1966)

The structural chemistry of the cyanide group has been reviewed recently by Britton.⁹⁹ The following generalizations appear to apply to short, intermolecular interactions of the cyanide group.

(1) Five atoms, at least, usually lie approximately on a straight line. These atoms are the two atoms of the cyanide group itself, the atom to which the cyanide group is attached most strongly, the acceptor atom, and an atom bonded to the acceptor atom (Figures 18–22).

(2) The strength of the interaction, judged by differences between the observed interatomic distances and those expected for normal van der Waals contacts, generally increases as the atomic weight of the acceptor atom increases, for atoms in a given group of the periodic table (Table V). The order of acceptor strengths toward the cyanide group, from interatomic distances, is $I > Br > Cl; Se > S; As > P; and Sn > Ge$.

TABLE V
OBSERVED AND CALCULATED INTERMOLECULAR DISTANCES
FOR SOME CYANIDES OF GROUPS IV–VII

| No. | Compound | Fig | Obsd inter-molecular distance, Å ⁹⁹ | Distance calcd from van der Waals radii, Å ^{7,70} | Shortening, Å |
|-----|--------------------------------------|-----|--|--|---------------|
| 1 | ClCN | | 3.01 | 3.30 | 0.3 |
| 2 | BrCN | | 2.86 | 3.45 | 0.6 |
| 3 | ICN | 18 | 2.79 | 3.65 | 0.9 |
| 4 | ICCCN | | 2.81 | 3.65 | 0.8 |
| 5 | IC ₆ H ₄ CN | | 3.18 | 3.65 | 0.5 |
| 6 | Se(CN) ₂ | 19 | 2.6 | 3.50 | 0.9 |
| 7 | P(CN) ₃ | | 2.85, 2.96 | 3.40 | 0.6, 0.4 |
| 8 | As(CN) ₃ | | 2.74 | 3.50 | 0.8 |
| 9 | CH ₃ As(CN) ₂ | | 2.94 | 3.50 | 0.6 |
| 10 | (CH ₃) ₂ AsCN | 20 | 3.18 | 3.50 | 0.3 |
| 11 | (CH ₃) ₃ GeCN | 21 | 3.57 | 3.6 | 0.0 |
| 12 | (CH ₃) ₃ SnCN | 22 | 2.45 | 4.0 | 1.6 |

For first-row elements (C, N, O, and F), the intermolecular interaction with a cyanide group is so weak it has not been observed. For last-row elements (*e.g.*, Pb and Bi, but also Sb and Te), the interaction is evidently so strong that crystals large enough for satisfactory X-ray crystallographic studies have been difficult to prepare.¹⁰⁰

(3) The length of the interaction for a given acceptor atom, *e.g.*, I, depends upon the nature of the acceptor atom's substituent on the side opposite the short intermolecular interaction. The better the opposite substituent is as a leaving group (*i.e.*, generally, the weaker it is—when an anion—as a Brønsted base), the shorter is the intermolecular interaction. For the iodine compounds I–CN, I–CCCN,¹⁰¹ and I–C₆H₄CN,¹⁰² for example (Table V, no. 3, 4, and 5), the

intermolecular interaction is shorter for the first two compounds, in which the carbon atoms of the substituents, –CN and –CCCN, are hybridized sp (and are, for carbon atoms, relatively weak bases¹⁰³), than it is for the third compound, in which the first carbon atom of the substituent, –C₆H₄CN, is hybridized sp².

In summary, the intermolecular interactions of the cyanide group are similar to those described earlier for other donor groups, both with respect to the stereochemistry of the interaction and with respect to the effect of chemical substitution upon the length of the interaction. As before, the “valence angle” at the acceptor atom is approximately 180°; the “valence angle” at the donor atom is normal (180° for the nitrogen atom of a cyanide group); and the length of the intermolecular “bond” decreases as the atomic weight of the acceptor atom in a given group of the periodic table increases and as the basicity of the leaving group decreases.

In the compounds R₂AsCN, R = CH₃ or CN, the length of the intermolecular interaction N···As decreases by about 0.2 Å each time a methyl group on the arsenic atom is replaced by a cyanide group (Table V, no. 7, 8, and 9). This shortening of the intermolecular bond may be an electronegativity effect,¹⁰³ in which case the same effect should be observed with fluorine.⁹⁹ Or, the shortening may reflect an internal movement of the lone pair on the arsenic atom toward the π-antibonding orbitals of the attached cyanide group(s). Intramolecular migration of electronic charge away from the arsenic atom's core would permit a lone pair on the nitrogen atom in an adjacent molecule to penetrate more deeply into the valence shell of the arsenic atom than would otherwise be possible.

2. Halogens and Interhalogens

a. Iodine monochloride

Solid-state interactions shorter than conventional van der Waals contacts but longer than conventional covalent bonds are the rule rather than the exception in interhalogen compounds, particularly those compounds that contain iodine. A simple example is iodine monochloride.

Iodine monochloride crystallizes in two forms.^{104,105} In both forms the ICl molecules are arranged in zigzag chains (Figure 23). These chains contain two types of ICl molecules. In molecules of one type, both kinds of atoms participate in short intermolecular interactions along the chain; these molecules are represented in Figure 23 by the open circles. In molecules of the other type (those represented in Figure 23 by the

(99) D. Britton, *Perspectives Struct. Chem.*, 1, 109 (1967).

(100) E. O. Schlemper, Ph.D. Thesis, University of Minnesota, 1965.

(101) B. Borgen, O. Hassel, and C. Rømming, *Acta Chem. Scand.*, 16, 2469 (1962).

(102) E. O. Schlemper and D. Britton, *Acta Cryst.*, 18, 419 (1965).

(103) H. A. Bent, *Chem. Rev.*, 61, 275 (1961).

(104) K. H. Boswijk, J. van der Heide, A. Vos, and E. H. Wiebenga, *Acta Cryst.*, 9, 274 (1956).

(105) G. B. Carpenter and S. M. Richards, *ibid.*, 15, 360 (1962).

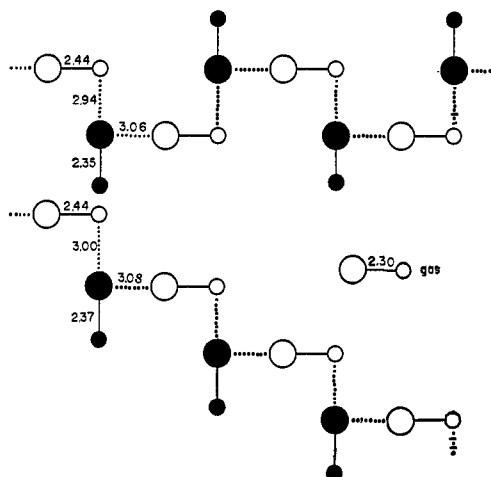

Figure 23.—Molecular chains in crystalline iodine monochloride: above, β -ICI; below, α -ICI.

filled circles), the chlorine atoms branch off the chain and are not involved in short intermolecular interactions. The branching chlorine atoms are *trans* to each other in β -ICI; in α -ICI they are *cis* to each other. Further, the chains in β -ICI are essentially planar while in α -ICI they are puckered. Otherwise, the two forms are very similar. In both forms the short intramolecular I-Cl distances are slightly longer than the internuclear distance in gaseous ICl, while the longer intermolecular distances Cl...I and I...I are 1 Å or so shorter than the corresponding van der Waals distances. For both forms the "bond" angles Cl(branching)—I...I and I—Cl...I have for simplicity been shown as right angles in Figure 23. The experimental values¹⁰⁵ are, respectively, 87 and 116° for β -ICI and 94 and 102° for α -ICI. These bond angles suggest that, in the intermolecular interactions along the chains, the chlorine atoms act chiefly as electron donors while the iodine atoms act either as electron acceptors (large, open circles) or (large, filled circles) as donors and acceptors, rather like the selenium atoms in the tetrahydroselephenone-iodine adduct (*vide supra*), and, more closely, like the iodine atoms in solid iodine.

b. Iodine

In solid iodine each atom participates in two, and each molecule in four, short intermolecular interactions. These interactions link the molecules together into planar sheets^{106,107} (Figure 24). The "bond" angles I—I*...I are approximately 90° when the central atom of the interaction, atom I*, is acting as an electron donor, and approximately 180° when the central atom is acting as an electron acceptor. Each atom (molecule) acts once (twice) in each capacity. The

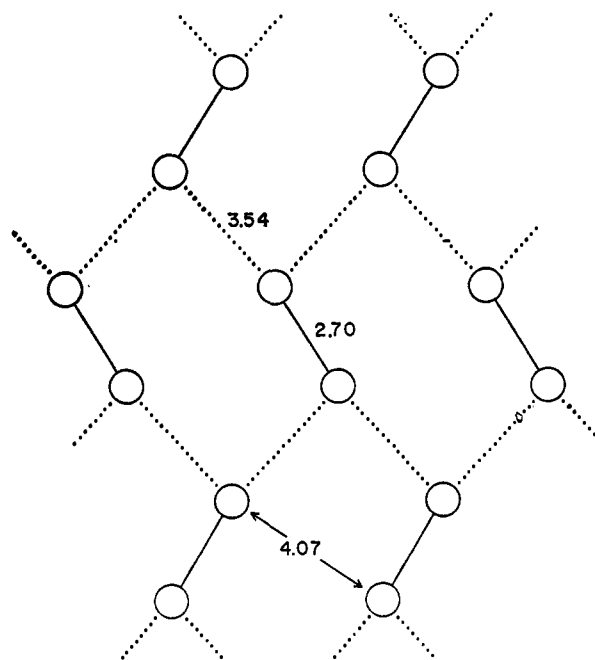

Figure 24.—Planar sheets in crystalline iodine.

two donor sites of an iodine molecule are *trans* to each other. The two acceptor sites of an iodine molecule lie along the molecular axis, approximately. These latter interactions may be compared with those of the bridging iodine molecule in I_8^{2-} (Figure 13). That the interactions are not exactly linear in solid iodine is probably due, in part, to a close nonbonded approach of 4.07 Å (arrow, Figure 24). This distance is 0.23 Å less than the expected van der Waals distance between two iodine atoms. Thus, through interactions reminiscent of those in the tetrahydroselephenone-iodine adduct (*vide supra*), each atom in solid iodine approaches the axial-type bonding found in ClF_3 and BrF_3 . The full development of this type of bonding is limited, however, by nonbonded interactions.

Bromine^{108,109} and chlorine¹¹⁰ have crystal structures very similar to that of iodine. For bromine, for example, the (donor)...(acceptor)—(acceptor substituent) "bond" angle is calculated from the data given by Wyckoff¹¹¹ to depart from linearity by 10° 22' at -23.5°; for iodine the corresponding value is 10° 2' at 26°. As observed previously, the greater the atomic weight of the acceptor atom, the more the short intermolecular distances depart from the values calculated from van der Waals radii. For Cl_2 , Br_2 , and I_2 , the differences between the calculated and observed intermolecular distances are, respectively, 0.3, 0.6,

(108) B. Vonnegut and B. E. Warren, *J. Am. Chem. Soc.*, **58**, 2459 (1936).

(109) L. L. Hawes, *Acta Cryst.*, **12**, 34 (1959).

(110) R. L. Collin, *ibid.*, **9**, 537 (1956).

(111) R. W. G. Wyckoff, "Crystal Structures," 2nd ed, Vol. 1, Interscience Publishers, New York, N. Y., 1963.

(106) P. M. Harris, E. Mack, Jr., and F. C. Blake, *J. Am. Chem. Soc.*, **50**, 1583 (1928).

(107) A. I. Kitaigorodskii, T. L. Khotsyanova, and Y. T. Struchkov, *Zh. Fiz. Khim.*, **27**, 780 (1953).

and 0.8 Å. These numbers are essentially the same as those obtained previously for the corresponding halogen cyanides (Table V, no. 1, 2, and 3).

Since chlorine and iodine have similar crystal structures, the question arises, "Why isn't the crystal structure of iodine monochloride similar to that of iodine?" In the iodine structure there are twice as many strong intermolecular interactions per molecule as there are in the iodine monochloride structure. With ICl in the I_2 structure, however, in a head-to-tail arrangement, which seems best, sterically, and with normal, chlorine...iodine donor-acceptor interactions, the nonbonded interaction that is 4.07 Å in I_2 would be only 3.5 Å, 0.45 Å less than the value predicted from van der Waals radii. Moreover, half the intermolecular interactions would be of the type (iodine-atom donor) ... (chlorine-atom acceptor). Now generally, in strong donor-acceptor interactions, the acceptor atom is as large as the donor atom. Usually it is larger. Interactions of the type (large donor atom) ... (smaller acceptor atom) exist; as a rule, however, they are relatively weak, owing, presumably, to the difficulty, sterically, of fitting the electron cloud of a large donor atom into, or nearly into, the valence shell of a smaller acceptor atom.^{111a}

c. Iodine trichloride

The difficulty of defining in terms of structural parameters the limits of a molecule in the solid state is well illustrated by the compound ICl_3 whose crystals contain discrete I_2Cl_6 groups¹¹² within which are interatomic distances significantly longer than normal covalent bonds but much shorter than ordinary van der Waals contacts (Figure 25). How best to describe the bonding within these groups has been an interesting problem in valence theory.^{59,66,112,113} The groups might be viewed as individual molecules in which the iodine atoms have in their valence shells six, or nearly six, electron pairs. Alternatively, the groups might be viewed as two strongly interacting ICl_3 molecules frozen in the midst of a halogen-atom exchange reaction. Or, the groups might be viewed as ICl_2^+ ions interaction with bridging Cl^- ions through four (chloride ion) ... (iodine atom) donor-acceptor interactions. The groups have been described,¹¹² also, as resonance hybrids of the two structures i and ii. This last formula-

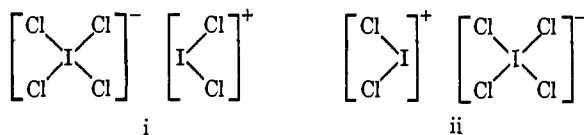

(111a) NOTE ADDED IN PROOF.—IBr has the I_2 structure (L. N. Swink and G. B. Carpenter, *Acta Cryst.*, B24, 429 (1968)) with intermolecular distances $Br \cdots IBr$ and $I \cdots BrI$ of 3.18 and 3.76 Å, respectively.

(112) K. H. Boswijk and E. H. Wiebenga, *ibid.*, 7, 417 (1954).

(113) A. F. Wells, "Structural Inorganic Chemistry," 3rd ed, Oxford University Press, London, England, 1962.

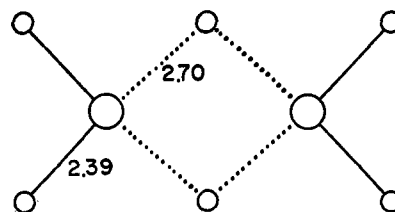

Figure 25.—Structure of the I_2Cl_6 groups in crystalline ICl_3 .

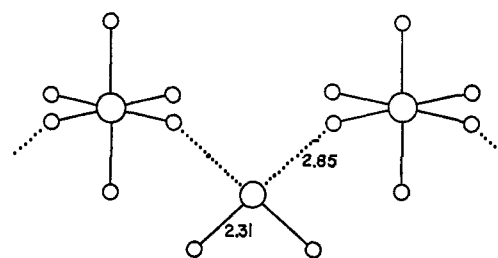

Figure 26.—Molecular chains in crystalline $ISbCl_5$, or $ICl_2^+ \cdot SbCl_6^-$.

tion expresses graphically the fact that in I_2Cl_6 the interactions between, for example, the iodine atoms and the bridging chlorine atoms are in length something between a conventional van der Waals contact and a conventional covalent bond. Additionally, the graphic formulation carries the implication that other properties of I_2Cl_6 are of intermediate character also. In particular, it implies that the electronic structure of the interaction between an iodine atom and a bridging chlorine atom is something between the electronic structure of a van der Waals contact and the electronic structure of a normal covalent bond.

Interactions similar to those in I_2Cl_6 occur in the compound $ISbCl_5$ ¹¹⁴ (Figure 26). This compound may be viewed as composed of polymeric molecules, $(ISbCl_5)_n$, in which the iodine and antimony atoms have in their valence shells nearly six electron pairs. Alternatively, the compound may be viewed as strongly interacting ICl_3 and $SbCl_5$ molecules frozen in the midst of a cooperative halogen-atom exchange reaction. Or, the compound may be viewed as ICl_2^+ and $SbCl_6^-$ ions interacting through (chlorine atom) ... (iodine atom) donor-acceptor interactions. The compound may be described, also, as a resonance hybrid of the structures $\{[ICl_4^-][SbCl_4^+]\}_n$ and $\{[ICl_2^+][SbCl_6^-]\}_n$, with the same implications as for I_2Cl_6 .

d. Profile of an exchange reaction

In I_2Cl_6 the short iodine-chlorine distances are longer and the longer iodine-chlorine distances are shorter than the corresponding distances in $ISbCl_5$ (Figures 25 and 26). This reciprocal relationship, the lengthening of an intramolecular interaction with a shorten-

(114) C. G. Vonk and E. H. Wiebenga, *Acta Cryst.*, 12, 859 (1959).

ing of a *trans* intermolecular interaction (until finally, perhaps, the two interactions become indistinguishable), appears to be a general phenomenon (Table VI).^{114a}

TABLE VI
IODINE-IODINE DISTANCES IN CRYSTALS

| Species | Short I-I distance, Å | Long I-I distance, Å | Fig |
|-------------------------------------|-----------------------|----------------------|-----|
| I ₂ (gas) | 2.67 | 4.30 ^a | |
| I ₂ (solid) | 2.70 | 3.54 | 24 |
| I ₇ ⁻ | 2.74 | 3.44 | 12 |
| I ₈ ²⁻ | 2.80 | 3.42 | 13 |
| I ₅ ⁻ | 2.81 | 3.17 | 11 |
| I ₃ ⁻ (unsym) | 2.83 | 3.03 | 10 |
| I ₆ ²⁻ | 2.85 | 3.00 | 13 |
| I ₃ ⁻ (sym) | 2.90 | 2.90 | 10 |

^a van der Waals distance.

Generally, too, the former effect is much less than the latter. In the formation of a molecular complex ABC through a donor-acceptor interaction A···B—C, the decrease in the length of the longer, intermolecular interaction A···B from the value expected for a normal van der Waals contact is generally five to ten times greater than the accompanying increase in the length of the shorter, intramolecular interaction B—C (Tables I and VI). This generalization is presented graphically in Figure 27, which has been constructed from the data in Table VI. The hyperbolic-like curve may be presumed to show, approximately, the changes that occur in the distances between nearest neighbors in the linear exchange reaction I₁ + I₂I₃ = I₁I₂ + I₃ when there are altogether 22 electrons in the valence shells of the three iodine atoms.

3. Organic Molecules with Oxygen Atoms as Electron Donors and Halogen Atoms as Acceptors

Short, linear (or nearly linear) intermolecular interactions of the type (oxygen atom)···(halogen atom)—(halogen-atom substituent) have been observed in crystals of N-chlorosuccinimide,¹¹⁵ O···Cl = 2.88 Å (van der Waals distance, vwd, = 3.20 Å); 2,4-dibromomenthone,¹¹⁶ O···Br = 2.88 Å (vwd = 3.35 Å); oxalyl bromide,^{117,118} O···Br = 3.27 Å (vwd = 3.35 Å); and beyerol monoethylidene iodoacetate,¹¹⁹ O···I = 3.12 Å (vwd = 3.55 Å). In these interactions the leaving group (the substituent attached to the halogen atom) is an organic group. Predictably, the interactions are longer—and presumably weaker—than those in which the leaving group is a halogen atom (Table I).

(114a) NOTE ADDED IN PROOF.—See also O. Hassel and C. Rømming, *Acta Chem. Scand.*, 21, 2659 (1967).

(115) R. N. Brown, *Acta Cryst.*, 14, 711 (1961).

(116) J. A. Wunderlich and W. N. Lipscomb, *Tetrahedron*, 11, 219 (1960).

(117) P. Groth and O. Hassel, *Proc. Chem. Soc.*, 343 (1961).

(118) P. Groth and O. Hassel, *Acta Chem. Scand.*, 16, 2311 (1962).

(119) A. M. O'Connell and E. N. Maslen, *Acta Cryst.* 21, 744 (1966).

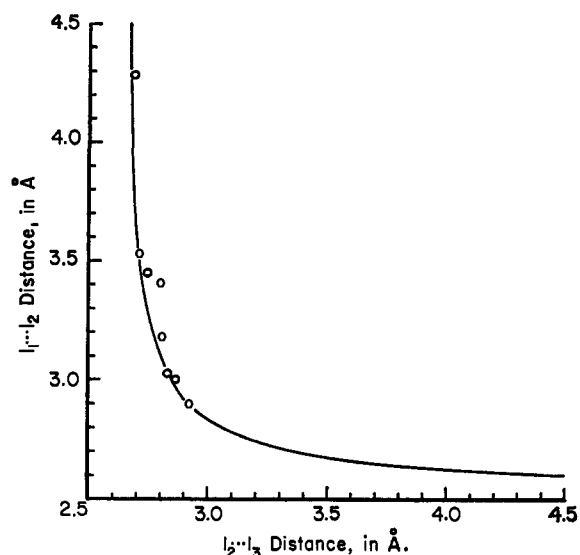

Figure 27.—Iodine-iodine distances in structures of the type I₁I₂I₃⁻.

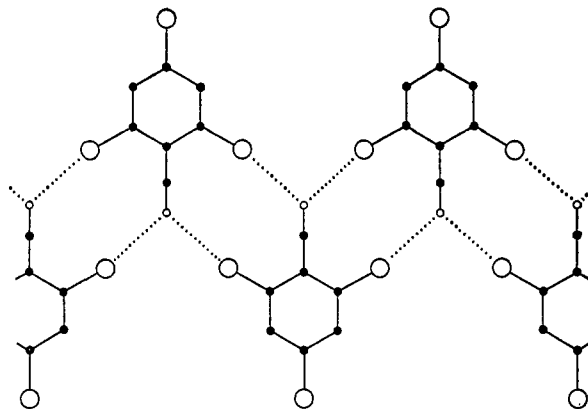

Figure 28.—Molecular sheets in crystalline tribromobenzonitrile.

Unusually short intermolecular oxygen···halogen interactions have been observed in *p*-chloriodoxybenzene,¹²⁰ O···I = 2.72 and 2.87 Å (vwd = 3.55 Å).

4. Molecules with Halogen Atoms as Electron Donors and/or Acceptors

Because of their exposed positions in many molecules, halogen atoms often participate in short, solid-state interactions. Many of these interactions are of the type already described. In the cyanuric halides, for example, linear nitrogen···halogen—carbon interactions link the molecules into puckered sheets.¹¹⁷

In tribromobenzonitrile, N···Br interactions link the molecules into planar, double chains⁹⁹ (Figure 28). If the C₆ rings in these chains are in benzenoid configurations, the nitrogen atoms would be hybridized sp and presumably could participate in only one, bifurcated, donor-acceptor interaction. If, on the other hand, the C₆ rings are in quinoid-type configurations (with

(120) E. M. Archer, *ibid.*, 1, 64 (1948).

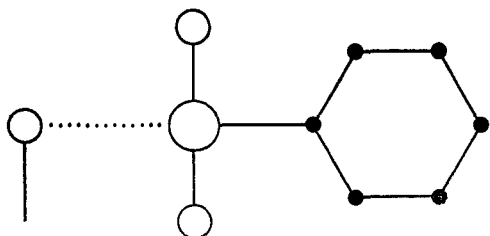

Figure 29.—Cl...I interactions in crystalline benzene iododichloride.

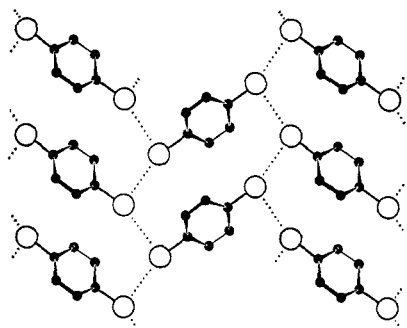

Figure 30.—Intermolecular interactions in crystalline *p*-dibromobenzene (cf. Figure 24).

respect to one, if not both electron spin sets; the observed interatomic distances are inclusive on this point), the nitrogen atoms would be hybridized sp^2 (for at least one spin set) and, like the oxygen atoms in the acetone-bromine adduct, could participate in two donor-acceptor interactions.

In benzene iododichloride, the chief binding forces in the crystal are Cl...I interactions,¹²¹ length 3.40 Å (vwd = 3.94 Å) (Figure 29). These interactions produce an environment about each iodine atom that, like the environments of the iodine atoms in ICl_3 and $ISbCl_5$ (Figures 25 and 26), approaches the square-planar environment of the tetravalent iodine atom in ICl_4^- .

The compound trithiazyl chloride, $(NSCl)_3$, contains sulfur-chlorine bonds. These bonds may act as electron acceptors off either end, and, indeed, in the solid state $(NSCl)_3$ contains both short $S...Cl$ interactions, length 3.41 Å (vwd = 3.65 Å), and short $N...S$ interactions, length 3.01 Å (vwd = 3.35 Å); the latter interactions produce a noticeable lengthening of the corresponding sulfur-chlorine bonds.¹²² The related compound sulfanuric chloride, $(NSOCl)_3$, contains short, linear $O...S...Cl$ interactions,¹²³ length 2.99 Å (vwd = 3.25 Å).

p-Dibromobenzene¹²⁴ (Figure 30) contains bromine-bromine contacts similar to those in solid bromine and iodine (Figure 24). Insertion of the

phenyl group between the primary donor and acceptor sites lengthens the $Br...Br$ interaction, however, from 3.30 Å in solid bromine to 3.76 Å in *p*-dibromobenzene (vwd = 3.90 Å); the increase is 0.46 Å. A similar change in ICN lengthens the intermolecular $N...I$ interaction 0.4 Å.⁹⁹

In thiuret hydriodide (1), each sulfur atom forms

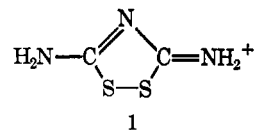

close contacts with two iodide ions.¹²⁵ The length of the interaction $I...S$ is 3.62 Å (vwd = 4.00 Å) when the "bond" $I...S$ is colinear with the sulfur-sulfur bond and slightly longer, 3.75 Å, when the $I...S$ "bond" is colinear with a sulfur-carbon bond.

Fluorine atoms do not act as primary acceptor sites in intermolecular interactions. Nor do they act as electron donor sites, of appreciable strength, when bound to small atomic cores. In the partially ionic compound trimethyltin fluoride, however, fluorine atoms are involved in nonlinear, unsymmetrical $Sn-F...Sn$ bridges in the solid state, and the coordination number of the tin atoms approaches five.¹²⁶ In dimethyltin fluoride, the fluorine atoms participate in linear, symmetrical $Sn...F...Sn$ bridges;¹²⁷ the coordination number of the tin atoms is six—more precisely, two, four (Figure 31). Dimethyltin fluoride may be viewed as linear dimethyltin cations⁹⁸ solvated by bridging fluoride ions.

5. Nearly Linear C-hal...hal-C Interactions

Unusual intermolecular interactions have been observed in several chlorine-containing compounds. Crystalline tetrachloroquinone (2), for example,

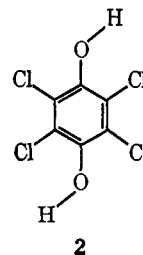

contains two types of short, intermolecular, chlorine...chlorine interactions¹²⁸ (Figure 32). In interactions of one type (Figure 32a), one $C-Cl...Cl$ angle is approximately 180° and the other $C-Cl...Cl$ angle, as expected, is approximately 90° (measured, 176 and

(121) E. M. Archer and T. G. D. van Schalkwyk, *Acta Cryst.*, **6**, 88 (1953).

(122) G. A. Wieggers and A. Vos, *ibid.*, **20**, 192 (1966).

(123) A. C. Hazell, G. A. Wieggers, and A. Vos, *ibid.*, **20**, 186 (1966).

(124) S. Bezzi and U. Croatto, *Gazz. Chim. Ital.*, **72**, 318 (1942).

(125) O. Foss and O. Tjomsland, *Acta Chem. Scand.*, **12**, 1799 (1958).

(126) H. C. Clark, R. J. O'Brien, and J. Trotter, *J. Chem. Soc.*, 2332 (1964).

(127) E. O. Schlemper and W. C. Hamilton, *Inorg. Chem.*, **5**, 995 (1966).

(128) T. Sakurai, *Acta Cryst.*, **15**, 443 (1962)

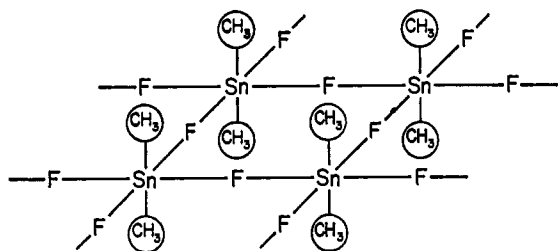

Figure 31.—Tin-fluorine interactions in dimethyltin fluoride.

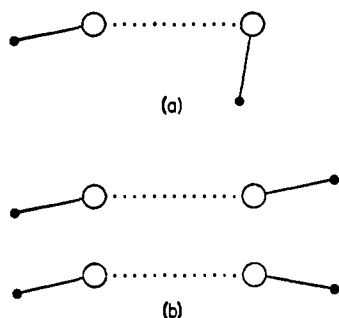
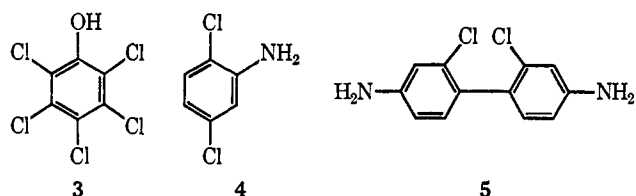

Figure 32.—Halogen...halogen interactions: (a) normal; (b) nearly linear.

80°, respectively). In interactions of the other type, however (Figure 32b), both C—Cl...Cl angles are approximately 180° (measured, 168°). Interactions of both types have been observed, also, in pentachlorophenol¹²⁹ (3). Only interactions of the latter type occur in 2,5-dichloroaniline¹³⁰ (4) and 2,2'-dichlorobenzidine¹³¹ (5).



Halogen atoms that participate in nearly linear C—hal...hal—C interactions are attached, in compounds 2–5, to aromatic rings, generally *meta* to a π donor, —NH₂ or —OH. In 2,4-dibromomenthone, which contains nearly linear C—Br...Br—C interactions,¹¹⁶ the halogen atoms are attached to carbonyl carbon atoms.

6. Carbonyl Compounds

The first-row elements carbon, nitrogen, oxygen, and fluorine generally do not act as electron acceptors, of noticeable strength, in intermolecular interactions. Short, intermolecular contacts between carbon atoms and oxygen atoms have been observed, however, in

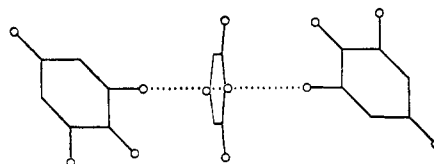
Figure 33.—Intermolecular interactions in alloxan (6) (after Bolton¹³³).

alloxan¹³² (6), triketoindane¹³³ (7), tetrachloro-*p*-benzoquinone¹³⁴ (8), parabanic acid¹³⁵ (9), and anhydrous barbituric acid¹³⁶ (10). These short, intermolecular, carbon...oxygen interactions in crystals of compounds 6–10 have the following characteristics: (1) the donor atom, presumably oxygen, is always the oxygen atom of a carbonyl group; (2) this carbonyl

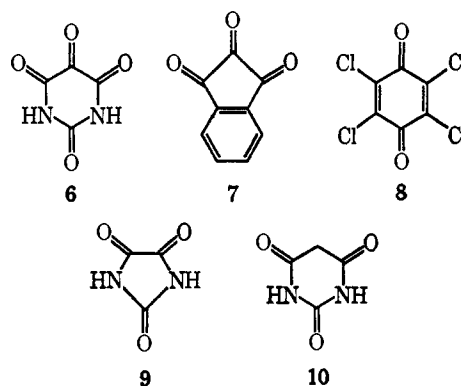

group is sometimes (compounds 6, 9, and 10), though not always (compounds 7 and 8), adjacent to an activating amino group; (3) the acceptor atom (or atoms), presumably carbon, is (or are) unsaturated; (4) the σ bonds of the donor carbonyl group and those of the acceptor atom(s) are approximately perpendicular to each other; (5) the angles C=O...C are approximately 150–160°; and (6) the short intermolecular distances, sometimes as short as 2.77 Å (vwd \approx 3.14 Å, or greater¹³⁷), generally come in clusters of three, with one distance in each cluster about 0.2 Å shorter than the other two.

A remarkable feature of the molecular arrangement in alloxan (6) is the complete absence of hydrogen bonding in the crystal.¹³² Each molecule participates, instead, in four, short, carbon...oxygen interactions, twice as an electron donor through the oxygen atoms of the α and γ carbonyl groups of the triketo group, probably through both lone pairs of each oxygen atom, and twice as an electron acceptor at the carbon atoms of the triketo group (Figure 33). The oxygen atom of one of these interactions is 2.79 Å from the central carbon atom (C _{β}) of a triketo group in an adjacent molecule and 2.97

(132) W. Bolton, *ibid.*, 17, 147 (1964).(133) W. Bolton, *ibid.*, 18, 5 (1965).(134) S. S. C. Chu, G. A. Jeffrey, and T. Sakurai, *ibid.*, 15, 661 (1962).(135) D. R. Davies and J. J. Blum, *ibid.*, 8, 129 (1955).(136) W. Bolton, *ibid.*, 16, 166 (1963).(137) H. P. Klug, *ibid.*, 19, 983 (1965).(129) T. Sakurai, *Acta Cryst.*, 15, 1164 (1962).(130) T. Sakurai, M. Sundaralingam, and G. A. Jeffrey, *ibid.*, 16, 354 (1963).(131) D. L. Smare, *ibid.*, 1, 150 (1948).

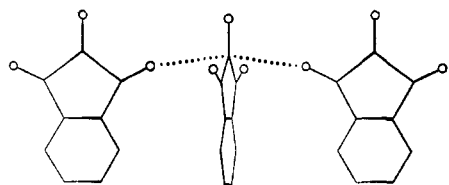

Figure 34.—Intermolecular interactions in triketoindane (7) (after Bolton¹³⁸).

Å from that triketo group's other carbon atoms (C_α and C_γ).

In triketoindane (7), the principal solid-state interactions are similar to those in alloxan, except that the relative orientation of the molecules is such that probably only one lone pair of each carbonyl group participates in an intermolecular interaction (Figure 34). Associated with each interaction is one short $O \cdots C_\beta$ distance, length 2.83 Å, and two equal, short $O \cdots C_{\alpha,\gamma}$ distances, length 3.02 Å.

The principal solid-state interactions in tetrachloro-*p*-benzoquinone (8) are shown in Figure 35. As in alloxan, both lone pairs of the carbonyl groups appear to participate in the intermolecular interactions. Each interaction has associated with it one short $O \cdots C$ distance, length 2.85 Å, and two longer $O \cdots C$ distances, lengths 3.06 and 3.14 Å. The principal intermolecular interactions in crystalline parabanic acid (9) are shown in Figure 36.

Interestingly,^{132,134} there are no short $O \cdots C$ interactions in crystalline succinimide (11), maleic anhydride (12), or *p*-benzoquinone (13).

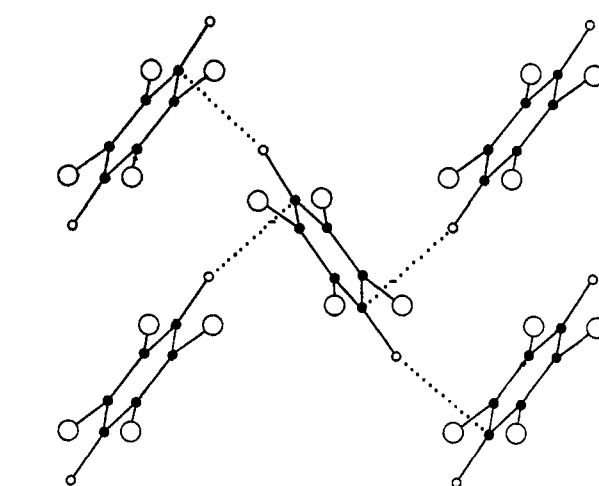
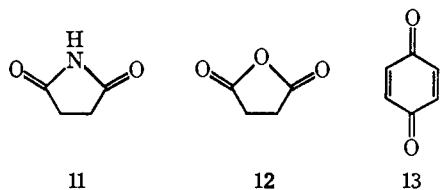

Figure 35.—Intermolecular interactions in tetrachloro-*p*-benzoquinone (8) (after Chu, Jeffrey, and Sakurai¹³⁴).

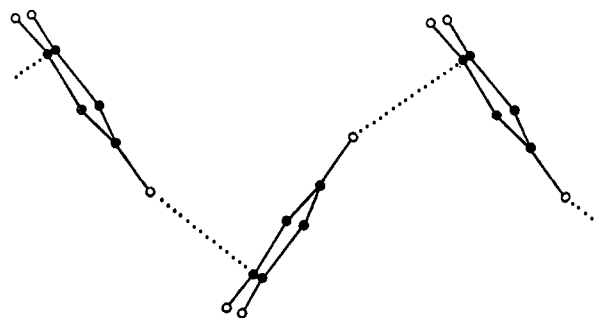

Figure 36.—Intermolecular interactions in parabanic acid (9) (after Chu, Jeffrey, and Sakurai¹³⁴).

also appear to participate in weak, donor-acceptor interactions in acetylbromoacetyl dihydroenmein.¹⁴²

C. RELATION TO THE WALDEN INVERSION

It has long been supposed that there is a close relation between the formation of molecular adducts and chemical reactions. Indeed, Neff suggested that, excluding reactions called ionic, a chemical reaction between two substances always first takes place by their union to form an addition product.¹⁴³ The converse of this statement had in effect been given by Kekulé, in his classic paper on "The Constitution and Metamorphoses of Chemical Compounds." In this paper Kekulé expressed the view that "Addition compounds... are aggregates of two molecules in which, under the particular conditions, the metamorphosis only proceeds to the state preceding the decomposition, that is to the state where the molecules associate. The reaction in a sense remains incomplete."¹⁴⁴ Kekulé's

In tetrahydroxy-*p*-benzoquinone,¹³⁷ violuric acid,¹³⁸ and dilituric acid,¹³⁹ carbonyl groups in adjacent molecules lie against each other sideways, head-to-tail, one group above and slightly to the side of the other, their σ bonds in parallel planes, with carbon \cdots oxygen separations of 3.09–3.15 Å.

Carbon atoms need not be trigonally hybridized to act as electron acceptors, albeit relatively weak ones, in intermolecular interactions. Crystalline dimethyl oxalate, for example, which melts 95° higher than diethyl oxalate, with marked changes in its Raman spectra,¹⁴⁰ contains nearly linear $O \cdots C(\text{methyl})-C$ interactions.¹⁴¹ Tetrahedrally hybridized carbon atoms

(138) B. M. Craven and Y. Mascarenhas, *Acta Cryst.*, **17**, 407 (1964).

(139) B. M. Craven, S. Martinez-Carrera, and G. A. Jeffrey, *ibid.*, **17**, 891 (1964).

(140) B. D. Saksena, *Proc. Indian Acad. Sci., Sect. A*, **12**, 416 (1940).

(141) M. W. Dougill and G. A. Jeffrey, *Acta Cryst.*, **6**, 831 (1953).

(142) M. Natsume and Y. Iitaka, *ibid.*, **20**, 197 (1966).

(143) J. U. Neff, *J. Am. Chem. Soc.*, **26**, 1577 (1904).

(144) A. Kekulé, *Ann. Chem. Pharm.*, **106**, 129 (1858). Translated by O. T. Benfey, "Classics in the Theory of Chemical Combination," Dover Publications, Inc., New York, N. Y., 1963, Paper 5.

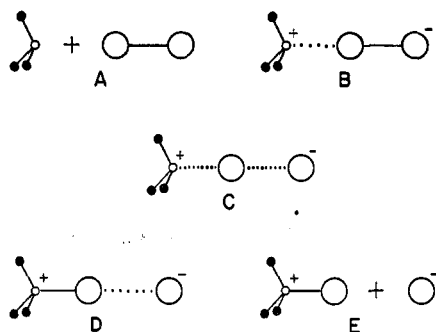

Figure 37.—Relation between the Hassel-type intermolecular interaction and the Walden inversion.

last sentence aptly describes the structures of the molecular addition compounds studied by Hassel and his co-workers.

Hassel's compounds may be viewed as the first step of a Walden inversion on a halogen atom (Figure 37). (The four substituents about the halogen atom are the second halogen atom and the first halogen atom's three unshared electron pairs.) Figure 37 shows, for the reaction between, for example, trimethylamine and iodine: (A) the reactants; (B) a Hassel-type addition compound between the reactants; (C) the reaction's transition state; (D) a Hassel-type addition compound between the products (an intimate ion pair); and (E) the solvent-separated products of the inversion reaction.

Walden's discovery of the inversion reaction "was a puzzle and a surprise," Frankland has written,¹⁴⁵ "for it did not fit into any pre-existing theory of optical activity, and had not been anticipated as a corollary to van't Hoff's theorem of the asymmetric carbon atom. It is highly probable," Frankland adds, "that it may mark an epoch in our views with regard to the mechanism of the process of substitution in general." Similar remarks seem appropriate regarding Hassel's discovery of the structures of the molecular adducts of Cl_2 , Br_2 , and I_2 .

Hassel's results were a puzzle and a surprise, for they did not fit into (at least were not correctly predicted by) the prevailing theory of molecular complex formation,^{17,29,73} and, generally, they had not been anticipated as a corollary to the theory of the tetrahedral atom, although many years earlier Werner had emphasized an important and relevant property of a tetrahedron.^{145,146} Werner pointed out that a tetrahedron has four faces toward which a central atom may be supposed to be capable of attracting external groups, forming thereby what Olson has called "face-centered bonds."¹⁴⁷ It seems probable that the discovery through X-ray crystallography of secondary, intermolecular, face-centered bonding will mark an im-

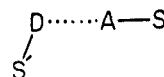

Figure 38.—Structural components of intermolecular interactions: D = electron donor; A = electron acceptor (Lewis acid, in case of face-centered bonds; Brønsted acid, in case of hydrogen bonds); S, S' = substituents.

portant step forward in our understanding of the stereochemistry of intermolecular interactions.

D. COMPARISON WITH HYDROGEN BONDS

1. Structural Similarities

a. Intermolecular

The important structural features of Hassel-type, face-centered bonds are summarized in Figure 38. This figure summarizes, also, the important structural features of hydrogen bonds.¹⁴⁸ For both types of bonds, D represents a donor atom, generally an atom with unshared electrons; A represents an acceptor atom, hydrogen in the case of hydrogen bonds and a heavier, generally somewhat electronegative atom in the case of face-centered bonds; S represents a "leaving group," generally a group that, as an anion, is a relatively weak base; and S' represents a substituent (possibly merely a lone pair) on the donor atom.

In hydrogen bonding, the acceptor molecule is called a Brønsted acid; in face-centered bonding, it is called a Lewis acid.

Generally, for both Lewis and Brønsted acids, the intermolecular interaction $\text{D}\cdots\text{A}$ (Figure 38) is shorter than a normal van der Waals contact but longer than a normal covalent bond; the angle $\text{D}\cdots\text{A}-\text{S}$ is nearly 180° , and the angle $\text{S}'-\text{D}\cdots\text{A}$ is normal for such an angle in the cation $(\text{S}'\text{DA})^+$.

As a consequence of these structural similarities, hydrogen bonds may often be substituted for face-centered bonds in crystals with little change in the main features of intermolecular bonding. Solid HF contains zigzag chains¹⁴⁹ not unlike those in solid iodine (Figure 24). Solid HCN contains linear chains¹⁵⁰ as does ICN (Figure 18). The 1:1 adduct formed by sulfuric acid and dioxane has a structure¹⁵¹ similar to that of the iodoform-dithiane adduct (Figure 7). And the structure of the linear, symmetrical adduct HF_2^- formed by HF and F^- may be compared with the structure of the adduct I_3^- (Figure 10b) formed by I_2 and I^- .¹⁵²

Often, the stronger the hydrogen bonds for different donor molecules interacting with a given Brønsted acid,

(145) P. F. Frankland, *J. Chem. Soc.*, 103, 613 (1913).

(146) A. Werner, *Ber.*, 44, 881 (1911).

(147) A. R. Olson, *J. Chem. Phys.*, 1, 418 (1933).

(148) G. C. Pimentel and A. L. McClellan, "The Hydrogen Bond," W. H. Freeman and Co., San Francisco, Calif., 1960.

(149) M. Atoji and W. N. Lipscomb, *Acta Cryst.*, 7, 173 (1954).

(150) W. J. Dulmage and W. L. Lipscomb, *ibid.*, 4, 330 (1951).

(151) O. Hassel and C. Rømming, *Acta Chem. Scand.*, 14, 398 (1960).

(152) J. C. Slater, *Acta Cryst.*, 12, 197 (1959).

the stronger, also, are the corresponding face-centered bonds for the same donor molecules interacting with a given Lewis acid (section II.A.2.e). However, toward the Lewis acid I_2 , the order of donor strength has been found to be $Se > S > O$.^{153,154}

Activation of an acceptor site follows similar, if not identical, principles for both types of interactions. The better an acceptor atom's substituent is as a leaving group, the stronger, generally speaking, is the corresponding intermolecular interactions, whether it is a hydrogen bond or a face-centered bond. Thus, acceptor strength increases in the order $A-CH_3 < A-CCH < A-Cl$ for atom A equal to hydrogen or iodine. Toward nitriles, however, the order of acceptor strength is reported to be $ICl > IBr > I_2$.¹⁵⁵

Like some hydrogen-bonding groups, atoms that participate in face-centered bonds may be amphoteric. The iodine atoms in solid iodine, for example, like the hydroxide groups in liquid water, act as both donors and acceptors of electrons in the formation of intermolecular bonds. Turning this statement around, one may say that, with regard to the formation of inter- and intramolecular bonds, the hydroxide group may be classified as a pseudo-halogen.

b. Intramolecular

Face-centered bonding, like hydrogen bonding, can occur intramolecularly. A good example is the short, "non-bonded," $O \cdots S$ interaction in the methyl ester of *o*-nitrobenzenesulfonic acid¹⁵⁶ (Figure 39). A similar interaction occurs in 2,5-dimethyldithiophophthene¹⁵⁷ (Figure 40). Replacement of the oxygen atom in the latter compound by sulfur produces a structure reported to have two equal sulfur \cdots sulfur distances, length 2.35 \AA ¹⁵⁸⁻¹⁶⁰ ($vwd = 3.70 \text{ \AA}$; single-bond distance = 2.10 \AA ¹⁶¹). In the unsymmetrical thiothiophthene derivative shown in Figure 41, however, the two sulfur \cdots sulfur distances are unequal.¹⁶² The structure of the corresponding selenium compound¹⁶³ is shown in Figure 42. In these intramolecular interactions (Figures 39-42) both the donor and the acceptor atoms are chalcogens. In each

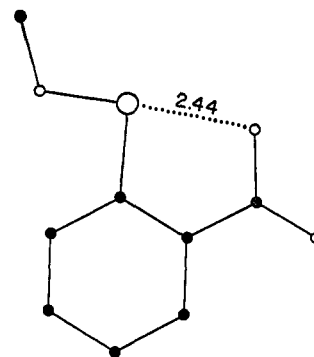

Figure 39.—Intramolecular $O \cdots S$ interaction in *o*-nitrobenzenesulfonic acid.

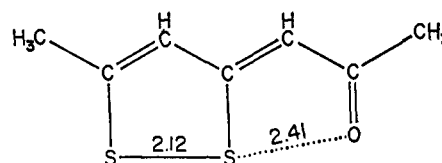

Figure 40.—Intramolecular $O \cdots S$ interaction in 2,5-dimethyldithiophophthene.

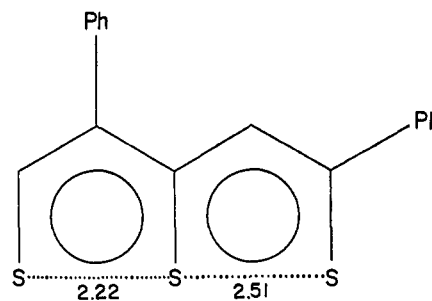

Figure 41.—Intramolecular $S \cdots S$ interactions in an unsymmetrical derivative of thiothiophthene.

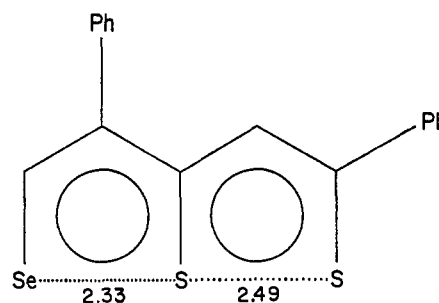

Figure 42.—Intramolecular $S \cdots S$ and $S \cdots Se$ interactions.

case, the interaction produces five-membered rings, which are planar.

In the anion and cation of 3-acetylimino-5-acetamido-1,2-dithiole (14), short, intramolecular $O \cdots S$ interactions occur off both ends of a sulfur-sulfur bond^{164,165} (Figure 43). In these ions there is, additionally, an

(153) J. D. McCullough and I. C. Zimmermann, *J. Phys. Chem.*, **65**, 888 (1961).

(154) H. Tsubomura and R. P. Lang, *J. Am. Chem. Soc.*, **83**, 2085 (1961).

(155) W. B. Person, W. C. Golton, and A. I. Popov, *ibid.*, **85**, 891 (1963).

(156) W. C. Hamilton and S. J. LaPlaca, *ibid.*, **86**, 2289 (1964).

(157) M. Mammi, R. Bardi, G. Traverso, and S. Bezzi, *Nature*, **192**, 1282 (1961).

(158) S. Bezzi, M. Mammi, and C. Garbuglio, *ibid.*, **182**, 247 (1958).

(159) S. Bezzi, C. Garbuglio, M. Mammi, and G. Traverso, *Gazz. Chim. Ital.*, **88**, 1226 (1958).

(160) M. Mammi, R. Bardi, C. Garbuglio, and S. Bezzi, *Acta Cryst.*, **12**, 1048 (1960).

(161) A. Hordvik, *Acta Chem. Scand.*, **20**, 1885 (1966).

(162) A. Hordvik, E. Sletten, and J. Sletten, *ibid.*, **20**, 2001 (1966).

(163) J. H. Van den Hende and E. Klingsberg, *J. Am. Chem. Soc.*, **88**, 5045 (1966).

(164) A. Hordvik and H. M. Kjøge, *Acta Chem. Scand.*, **20**, 1923 (1966).

(165) A. Hordvik and E. Sletten, *ibid.*, **20**, 2043 (1966).

oxygen atom from another molecule near the disulfide group, in a triangular arrangement (Figure 43).

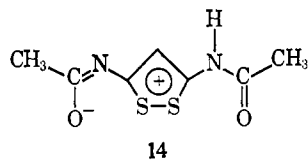

Analogous interactions occur between halide ions and the disulfide group of the thiuret ion (15) in thiuret hydrochloride,¹⁶⁶ bromide,¹⁶⁷ and iodide¹²⁵ (Figure 44). The difference between a normal van der Waals contact distance and the observed halogen...sulfur distance in these compounds is greatest for the iodide and least for the chloride; correspondingly, the sulfur-sulfur bond is longest in the iodide (2.08 Å) and shortest in the chloride (2.06 Å).¹⁶⁸

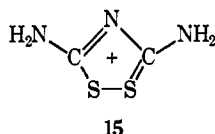

The environment of the disulfide group of the 4-phenyl-1,2-dithiolium ion (16) in 4-phenyl-1,2-dithiolium iodide¹⁶⁸ is essentially the same as the environment of the disulfide ion in thiuret hydriodide. In the 3-phenyl-substituted ion, however, one of the (approximately) linear $I \cdots S-S$ interactions is absent;¹⁶⁹ the sulfide group is attacked off only one end, presumably owing to steric shielding of the other end by the phenyl group.

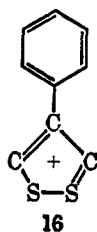

A close, intramolecular, nonbonded approach between sulfur and phosphorus atoms occurs in $P_4S_3I_2$.¹⁷⁰ Mention should be made, also, of the often-discussed, short, sulfur...sulfur distance in S_4N_4 ^{171,172} (Figure 45).

2. Spectroscopic Similarities

When an acid A-S forms a complex (Figure 38), its color changes, sometimes in the visible and ultraviolet regions of the spectrum and often, also, in that part of the spectrum associated with the normal mode of the

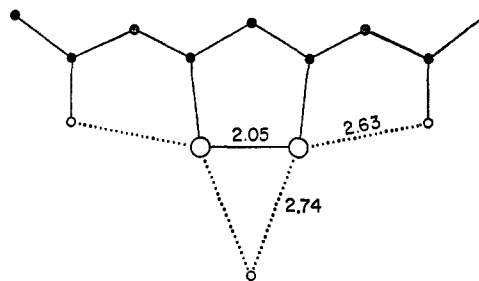

Figure 43.—Inter- and intramolecular interactions of the disulfide group of the ion of 3-acetylthio-5-acetimidodithiolium (14).

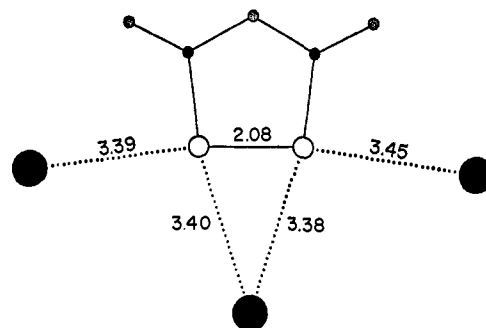

Figure 44.—Interactions of halide ions (large filled circles) with the disulfide group (large open circles) of the thiuret ion (15).

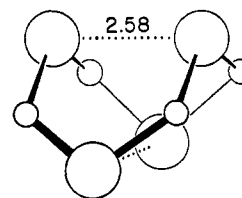

Figure 45.—Intramolecular S...S interactions in S_4N_4 .

acid-base complex that involves mainly a stretching of the A-S bond. This is so whether the acid A-S is a Brønsted acid (A = a hydrogen atom) or a Lewis acid (A = a heavier atom). Thus, as is well known, hydrogen bonding produces characteristic changes in the infrared spectra of Brønsted acids in the region of the H-S stretching frequency.¹⁴⁸ Face-centered bonding produces similar changes in the infrared spectra of Lewis acids.^{73,173-176} For example, with an increase in strength of the donor-acceptor bond $D \cdots A$ and with, correspondingly, a decrease in strength of the acceptor-acceptor substituent bond A-S, for A equal to hydrogen or, e.g., iodine (S equal to Cl^{173} or CN^{174}), there is in the A-S stretching mode: (1) a decrease in stretching frequency and force constant; (2) an in-

(166) A. Hordvik and J. Sletten, *Acta Chem. Scand.*, **20**, 1907 (1966).

(167) A. Hordvik and S. Joys, *ibid.*, **19**, 1539 (1965).

(168) A. Hordvik and E. Sletten, *ibid.*, **20**, 1874 (1966).

(169) A. Hordvik and H. M. Kjølge, *ibid.*, **19**, 935 (1965).

(170) D. A. Wright and B. R. Penfold, *Acta Cryst.*, **12**, 455 (1959).

(171) C. Lu and J. Donohue, *J. Am. Chem. Soc.*, **66**, 818 (1944).

(172) D. Clark, *J. Chem. Soc.*, 1615 (1952).

(173) W. B. Person, R. E. Humphrey, W. A. Deskin, and A. I. Popov, *J. Am. Chem. Soc.*, **80**, 2049 (1958).

(174) W. B. Person, R. E. Humphrey, and A. I. Popov, *ibid.*, **81**, 273 (1959).

(175) W. B. Person, R. E. Erickson, and R. E. Buckles, *ibid.*, **82**, 29 (1960).

(176) H. B. Friedrich and W. B. Person, *J. Chem. Phys.*, **44**, 2161 (1966).

crease in half-intensity width; and (3) an increase in the integrated absorption coefficient. In going from the solvent carbon tetrachloride to pyridine, for example, the frequency of the fundamental absorption band of iodine monochloride changes from 375 to ~ 270 cm^{-1} , the force constant changes from 2.27 to ~ 1.18 $\text{mdyn}/\text{\AA}$, the half-intensity width changes from 8 to ~ 30 cm^{-1} , and the integrated intensity changes from 1.0 to ~ 8 $\text{cm}^{-1} \text{ cm}^2/\text{mmole}$.¹⁷³ (Solutions of iodine cyanide in carefully purified dioxane have been noted to have two absorption peaks in the region of the I-C stretching frequency.¹⁷⁴ These peaks probably arise from the presence of two types of donor sites in dioxane molecules: the equatorial and axial lone pairs on the oxygen atoms; cf. Figures 8 and 9.)

Face-centered bonding is similar, spectroscopically, to hydrogen bonding in another respect. Trihalide ions such as ICl_2^- and Br_3^- have stretching interaction constants, f_{rr} , that, relative to their bond-stretching force constants, F_r , are unusually large.¹⁷⁷ The only triatomic molecule or ion with a larger value for the ratio r_r/f_r appears to be the ion HF_2^- .¹⁷⁷

Finally, from a study by nmr of dimethylpropionamide solutions, it has been concluded that the Lewis acid iodine may interact with nitrogen in a manner similar to that of protonic acids in water.¹⁷⁸

3. Other Similarities (Summary)

Two types of intermolecular bonds may be distinguished in condensed systems: face-centered bonds and hydrogen bonds. Compared with van der Waals interactions, these bonds are relatively strong, highly directional, and easily saturated. They involve the sharing of electrons between a donor atom in a "base" and a coordinatively unsaturated acceptor atom in an "acid." Face-centered bonds correspond to the first steps of bimolecular nucleophilic displacement reactions. Hydrogen bonds correspond to the first steps of proton-transfer reactions. Both bonds produce an increase, albeit perhaps small, in the ligancies of the donor and acceptor atoms and an increase, though again perhaps small, in the number of electrons in the valence shells of the acceptor atoms.

E. THEORETICAL DESCRIPTIONS

"When the textures of two substances are mutually contrary, so that hollows in the one correspond to projections in the other and *vice versa*, then connection between them is most perfect."^{178a}

Four types of models have been used to describe the formation of molecular complexes.

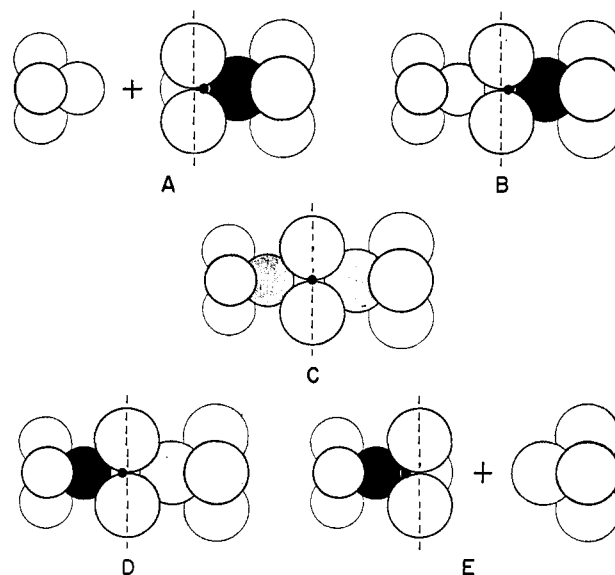

Figure 46.—Tangent-sphere representation of face-centered bonding and the Walden inversion; cf. Figure 37. Each sphere represents a valence-shell electron pair. Black spheres represent bonding pairs. Gray spheres represent electron pairs of face-centered, or "pair-pocket," bonds.⁶⁵

One of the earliest models of chemical interaction was a geometrical model proposed by Lémery: "[C]hemical combination between two substances, such as an acid and a base, might be accounted for by supposing that the particles of the one substance were sharp, and those of the other porous, and that combination was affected by the *fitting of the points into the holes*."¹⁷⁵ The principal factors of Lémery's model are present today in the lock-and-key model of biochemical interactions,¹⁷⁹ the bumps-in-hollows model of molecular crystals,¹⁸⁰ and the pair-pocket model of donor-acceptor interactions⁶⁵ (Figure 46). (The explanation for the presence of bumps and hollows in the outer envelope of a molecule's electron cloud lies, presumably, in the operation of the physical factors that are described by the several terms in the quantum-mechanical Hamiltonian. Particularly important are the non-classical kinetic energy terms. Combined with the action of the Exclusion principle, these factors produce electron clouds whose shapes resemble, somewhat, the graphic formulas of classical structural chemistry.)

Thus, geometrically, intermolecular interactions have been described by these phrases:

- (1) points-in-holes
- (2) locks-in-keys
- (3) bumps-in-hollows
- (4) pairs-in-pockets

Chemically, intermolecular interactions (interactions,

(177) W. B. Person, G. R. Anderson, J. N. Fordemwalt, H. Stammreich, and R. Forneris, *J. Chem. Phys.*, **35**, 908 (1961).

(178) R. S. Drago and D. Bafus, *J. Phys. Chem.*, **65**, 1066 (1961).

(178a) Lucretius, "On the Nature of the Universe." Book VI. "Meteorology and Geology," R. Latham, translator, Penguin Books, Baltimore, Md., 1965.

(179) J. D. Watson, "Molecular Biology of the Gene," W. A. Benjamin, Inc., New York, N. Y., 1965.

(180) A. I. Kitaigorodskii, "Organic Chemical Crystallography," Consultants Bureau, New York, N. Y., 1961.

particularly, that do not involve hydrogen) have been described by these phrases:

- (5) saturation of residual affinities^{181,182}
- (6) exaltation of valency¹⁸²
- (7) secondary acid-base interactions¹⁸³
- (8) donor-acceptor interactions⁷³
- (9) face-centered bonding¹⁴⁷
- (10) intermolecular semipolar bonding¹⁸⁴
- (11) initial step of a Walden inversion

Physically, intermolecular interactions have been described by these phrases:

- (12) adhesion by stray feeler lines of force^{2,185-188}
- (13) adhesion by attraction of positive and negative patches in molecules¹⁸⁶
- (14) electron clutching
- (15) charge sharing
- (16) charge transfer^{29,73,189,190}

Quantum-mechanically, intermolecular interactions have been described by these phrases:

- (17) complex resonance¹⁹¹
- (18) no-bond - dative-bond resonance²⁹
- (19) filling of antibonding orbitals¹⁹²
- (20) interaction of the highest occupied orbitals with the lowest vacant orbitals

These phrases are all useful, and complementary. They emphasize different aspects of intermolecular interactions. Some phrases emphasize the saturation and directional character of strong, intermolecular interactions (1-4, 5, 9). Several phrases emphasize the intermediate length and strength of intermolecular bonds (5, 7, 12, 18); or their similarity to normal bonds (6, 10, 15); or the creation of formal charges (10, 16, 18) and expanded octets (6); or the fact that, like intramolecular bonding, intermolecular bonding is essentially an electrostatic phenomenon (12-16).

A number of the phrases imply that intermolecular interactions can be described (to a first approximation) in terms of properties of the isolated molecules¹⁹³—bumps and hollows, for example, positive patches, vacant orbitals, and so forth (1-4, 5, 7, 8, 13, 19, 20). Broadly speaking, the following words or phrases are equivalent to each other: point \approx key \approx bump \approx unshared electron pair \approx negative patch \approx terminus of

stray feeler lines of force; hole \approx lock \approx hollow \approx pocket \approx face \approx positive patch \approx origin of stray feeler lines of force; molecule with a high-lying occupied orbital \approx donor \approx nucleophilic reagent \approx base; molecule with a low-lying vacant orbital \approx acceptor \approx electrophilic reagent \approx acid.

That the driving force behind the formation of intermolecular bonds stems chiefly from increased nuclear-electron attractions is suggested by several of the phrases (4, 8, 12-16, 19, 20). Intermolecular interactions of the type shown in Figure 46 could hardly arise from a decrease in electron-electron repulsions or nuclear-nuclear repulsions, or from a decrease in electronic kinetic energy.

The importance of the chemical nature of the substituent attached to the acceptor atom is implied in several of the descriptions. For a coulombically deep hole, hollow, lock, or pocket (1-4); for effective electron clutching (14) or charge sharing (15) through a secondary acid-base interaction (7), a face-centered bond (9), or intermolecular resonance involving a dative bond (18); for a σ antibonding orbital to have a dense lobe off the acceptor atom's end of a bond—for all these things the substituent attached to the acceptor atom should be an electronegative atom.

The importance of the chemical nature of the acceptor atom is implied in several of the descriptions, also. To have a geometrically large, sterically free hole, hollow, lock, pocket, or lobe of an antibonding orbital (1-4, 19), the acceptor atom should have a large core and less than its maximum covalence (6).

The existence of a relation between inter- and intramolecular bonding⁵ is suggested by several of the descriptions (5, 7, 10, 11, 17, 18, and Figure 46). This relation may be illustrated with an orbital description of the formation of a triiodide ion from an iodide ion and an iodine molecule.

Assume that an iodide ion I_a^- approaches an iodine molecule I_bI_c off atom I_b 's end of the iodine-iodine bond. Let a , b , and c represent p_σ orbitals on atoms I_a , I_b , and I_c , respectively, oriented so that overlapping lobes have the same sign. Initially, when the distance $I_a \cdots I_b$ is large and the distance I_b-I_c is that of a normal iodine-iodine bond, the wave function that describes the approaching lone pair of the I_a^- ion and the bonding pair of the I_b-I_c molecule may be represented by an antisymmetrical, determinantal function^{194,195} built up from the space functions a and $(b + c)$; normalizing constants are not shown. a represented the lone pair orbital of I_a^- ; $(b + c)$ represents the bonding orbital in I_bI_c . As the ion approaches the molecule, the lone pair will begin to occupy a region of space where the electrostatic energy stems

(181) G. T. Morgan, S. R. Carter, and W. F. Harrison, *J. Chem. Soc.*, 127, 1917 (1925).

(182) J. Weiss, *ibid.*, 245 (1942).

(183) G. N. Lewis and G. T. Seaborg, *J. Am. Chem. Soc.*, 61, 1886 (1939).

(184) R. B. Woodward, *ibid.*, 64, 3058 (1942).

(185) J. Stark, translated by D. A. Hahn and M. E. Holmes, *ibid.*, 37, 2611 (1915).

(186) N. R. Campbell, "Modern Electrical Theory," 2nd ed, Cambridge University Press, London, 1913, Section 129.

(187) J. J. Thomson, *Phil. Mag.*, 27 (6), 757 (1914).

(188) W. H. Rodebush, *Chem. Rev.*, 5, 522 (1923).

(189) S. P. McGlynn, *ibid.*, 58, 1113 (1958).

(190) J. N. Murrell, *Quart. Rev. (London)*, 15, 191 (1961).

(191) W. Brackman, *Rec. Trav. Chim.*, 68, 147 (1949).

(192) J. F. A. Williams, *Tetrahedron*, 18, 1477 (1962).

(193) J. I. Musher and L. Salem, *J. Chem. Phys.*, 44, 2943 (1966).

(194) J. C. Slater, *Phys. Rev.*, 34, 1293 (1929).

(195) J. A. Pople, *Quart. Rev. (London)*, 11, 273 (1957)

partly from the presence of atom I_a and partly from the presence of atoms I_b and I_c . The wave function of an electron in this semibonding region may be expressed, in terms of the orbital a of atom I_a and the antibonding orbital $b - c$ of the iodine molecule, as the linear combination $a + \lambda(b - c)$. The coefficient λ indicates the extent to which the antibonding orbital is occupied by the approaching pair. (Because the energy of the antibonding orbital $b - c$ decreases as the distance between atoms I_b and I_c increases, the formation of a complex between the donor I_a^- and the molecule I_bI_c lengthens (and weakens) the bond I_b-I_c (Figure 27).) The wave function for both pairs of electrons in the bonding regions of the complex $I_a^- \cdot I_bI_c$ may be written as a determinantal function built up from the space functions $a + \lambda(b - c)$ and $b + c$. Since a determinant's value is not altered when one of its columns or rows is added to another column or row, the determinantal function built up from the space functions $a + \lambda(b - c)$ and $b + c$ is mathematically equivalent to the determinantal function built up from the space functions $a + 2\lambda b$ and $b + c$. When λ is $1/2$, the first space function becomes $a + b$. The two space functions $a + b$ and $b + c$ may be interpreted as representing two electron-pair bonds, one between atoms I_a and I_b and the other between atoms I_b and I_c . Alternatively, the determinantal wave function may be built up from, for example, the space functions $a + 2b + c$ and $a - c$,^{66,196} called molecular orbitals—more precisely, delocalized molecular orbitals. Such orbitals are useful in discussing the symmetry of the charge distribution in electronically excited states of molecules. (The conventional Hückel molecular orbitals are $a + \sqrt{2}b + c$ and $a - c$, from which may be obtained, by a linear transformation, the mathematically equivalent, linearly independent—but not orthogonal—space functions $a + (\sqrt{2}/2)b$ and $(\sqrt{2}/2)b + c$.) The space functions $a + b$ and $b + c$ (or $a + (\sqrt{2}/2)b$ and $(\sqrt{2}/2)b + c$) may be called localized molecular orbitals,¹⁹⁷ or equivalent orbitals,^{195,198–200} they are useful in discussing the charge distributions in the ground states of molecules. Mathematically, if not chemically, there are, thus, three essentially equivalent descriptions of the triiodide ion: (1) filling of localized molecular orbitals, space functions $a + b$ and $b + c$ (in the simple Hückel approximation, $a + (\sqrt{2}/2)b$ and $(\sqrt{2}/2)b + c$); (2) filling of delocalized molecular orbitals, space functions $a + 2b + c$ (in the simple Hückel approximation, $a + \sqrt{2}b + c$) and $a - c$; and (3) filling of a bonding orbital and a lone-pair-anti-

bonding-orbital orbital, space functions $b + c$ and $a + \lambda(b - c)$, in which, for a symmetrical triiodide ion, $\lambda = 1/2$.

The question is sometimes raised,⁶⁶ "Does the central atom in an ion such as the triiodide ion violate the Octet rule?" If one means by this question, "Is it necessary in giving an approximate description of the space functions of an approximate wave function for the ion's valence-shell electrons to use more than four orbitals centered at the central atom?," the answer is no. If one means, however "Are there more than eight electrons in the vicinity of the central atom's valence-shell?," the answer is probably yes.

As the above questions indicate, the octet rule is currently used in two senses: in an older sense, the sense used by Lewis²⁰¹ and Langmuir,²⁰² to refer to the number of electrons in an atom's valence shell; and in a newer sense, the sense used in molecular orbital theory, to refer to the number of atomic orbitals used to describe an approximate wave function for a molecule's valence-shell electrons. The older use focuses attention upon a physical conjecture; the newer use focuses attention upon a mathematical approximation. To describe accurately the wave function for the valence-shell electrons of, for example, methane, would require, however, a large number of atomic-like orbitals centered at the carbon nucleus. Still, one would not normally suppose that the carbon atom of methane violates the Octet rule. One might suppose, however, on the basis of the p-orbital model, that such compounds as NeF_2 , OF_4 , and NF_5 could be synthesized.

The antibonding orbital model may be criticized on the grounds that conventional antibonding orbitals are not sufficiently localized to describe accurately the interaction between an acceptor molecule and an electron pair that is held tightly to an electronegative atom in a donor molecule. What are needed are localized antibonding orbitals. This need becomes particularly apparent when one attempts to describe the intermolecular interactions of a carbonyl group, whose conventional, lowest lying vacant orbital, the π antibonding orbital of the double bond, has four lobes, only one of which can overlap effectively with a lone-pair orbital in intermolecular interactions of the type represented by the dotted lines in Figures 33–36. Additionally, it may be noted that conventional, "unhybridized," σ -type antibonding orbitals are inappropriate for describing face-centered bonds to octahedrally coordinated atoms.

The stereochemistry of interactions of carbonyl groups with electron-pair donors has been the subject of many discussions.²⁰³ From the results summarized in Figures 33–36, it would appear that some, if not all,

(196) G. C. Pimentel, *J. Chem. Phys.*, **19**, 446 (1951).

(197) C. Edmiston and K. Ruedenberg, *ibid.*, **43**, S97 (1965).

(198) J. Lennard-Jones, *Proc. Roy. Soc. (London)*, **198**, 1 (1949).

(199) G. G. Hall and J. Lennard-Jones, *ibid.*, **202**, 155 (1950).

(200) J. Lennard-Jones and J. A. Pople, *ibid.*, **202**, 166 (1950).

(201) G. N. Lewis, *J. Am. Chem. Soc.*, **38**, 762 (1916).

(202) I. Langmuir, *ibid.*, **41**, 868 (1919).

(203) M. L. Bender, *Chem. Rev.*, **60**, 53 (1960).

TABLE VII
INTERATOMIC DISTANCES (ÅNGSTRÖMS) IN CRYSTALS OF THE HEAVIER ELEMENTS OF GROUPS V, VI, AND VII

| Element | Distance to atom's nearest neighbor(s), D_1^a | Calcd single-bond distance ⁷⁰ | Distance to atom's next-nearest neighbors, D_2^a | van der Waals distance (vwd) | vwd - D_2 | $D_2 - D_1$ |
|---------|---|--|--|------------------------------|-------------|-------------|
| As | 2.51 (3) | 2.52 | 3.15 (3) | 4.00 | 0.85 | 0.64 |
| Sb | 2.87 (3) | 2.96 | 3.37 (3) | 4.40 | 1.03 | 0.50 |
| Bi | 3.10 (3) | 3.27 | 3.47 (3) | ... | ... | 0.37 |
| Se | 2.32 (2) | 2.38 | 3.46 (4) | 4.00 | 0.54 | 1.14 |
| Te | 2.86 (2) | 2.77 | 3.74 (4) | 4.40 | 0.66 | 0.88 |
| Cl | 2.02 (1) | 1.93 | 3.34 (2) | 3.60 | 0.26 | 1.32 |
| Br | 2.27 (1) | 2.29 | 3.30 (2) | 3.90 | 0.60 | 1.03 |
| I | 2.70 (1) | 2.60 | 3.54 (2) | 4.30 | 0.76 | 0.84 |

^a Number of such neighbors in parentheses.

intermolecular interactions of the carbonyl group may be classified as Hassel-type, pair-pocket, face-centered bonds, in which, in Figures 33-36, the oxygen atom of one carbonyl group approaches a carbon atom of another carbonyl group opposite one of the two equivalent orbitals that the carbon atom uses in its double bond.^{203a} Interestingly, such interactions may place the oxygen atom nearer a carbon atom with which it does not share electrons than it does to that (or those) carbon atom(s) with which it does share electrons (Figures 33 and 34).

It is not immediately apparent how best to describe in terms of Hassel-type, donor-acceptor interactions the benzene-bromine and xylene-carbon tetrabromide complexes (Figures 16 and 17). Also a puzzle are the nearly linear C-hal...hal-C interactions illustrated in Figure 32b.

F. INCIPIENT OCTET EXPANSIONS IN INORGANIC SYSTEMS

1. Elements of Groups V, VI, and VII

Table VII gives the distances to an atom's nearest and next-nearest neighbors in crystals of the heavier elements of groups V, VI, and VII.^{111,113} Atoms in these crystals have $8 - N$ nearest neighbors, where N is the ordinal number of the element's group in the periodic table (5 for As, Sb, and Bi; 6 for Se and Te; 7 for Cl, Br, and I). Distances to these nearest neighbors (column 2) are generally within 0.1 Å of the distances calculated⁷⁰ for normal single bonds between such atoms (column 3). In these crystals an atom evidently has in its valence shell, from nearest-neighbor interactions alone, $8 - N$ shared electron pairs. If next-nearest-neighbor interactions are ignored, and if nearest-neighbor interactions are assumed to be normal, two-center bonds, the number of unshared electron pairs in an atom's valence shell is $[N - (8 - N)] \times \frac{1}{2} = N - 4$. This number is 1 for As, Sb, and Bi; 2 for Se and Te; and 3 for Cl, Br, and I. The total number of electron pairs, shared or unshared, in an atom's valence is $[N + (8 - N)] \times \frac{1}{2}$, or $(8 - N) + (N - 4)$, *i.e.*, 4.

(203a) NOTE ADDED IN PROOF.—For further data on the stereochemistry of the acceptor sites of the carbonyl group, see S. R. Hall and F. R. Ahmed, *Acta Cryst.*, B24, 337, 346 (1968).

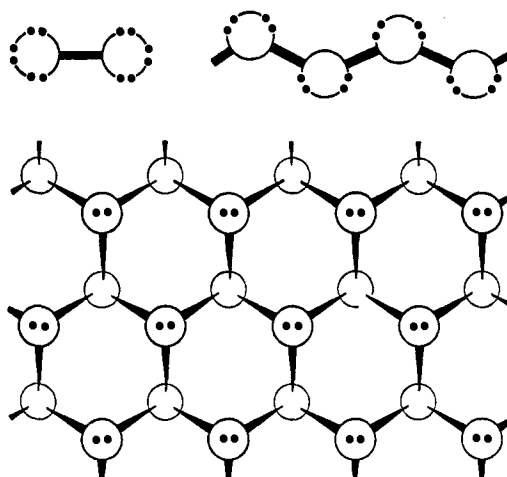

Figure 47.—Molecular entities in crystals of the heavier elements of groups V, VI, and VII (after Wells¹¹³): filled circles, unshared electrons.

To a first approximation, *i.e.*, from the point of view of nearest-neighbor interactions alone, atoms in these crystals obey the Octet rule. In this approximation, the crystals may be described¹¹³ as composed of puckered layers, helical chains, or diatomic molecules (Figure 47), according as the number of unshared valence-shell electron pairs per atom is, respectively, 1, 2, or 3.

To a second approximation, next-nearest-neighbor interactions should be considered. Their lengths (Table VII, column 4) are significantly less than the corresponding van der Waals distances (column 5). In every case the shortening, (van der Waals distance) - (observed next-nearest-neighbor distance), increases with increasing atomic number within a given group of the periodic table (column 6); correspondingly, the difference between nearest- and next-nearest-neighbor distances decreases (column 7). Indeed, in the low-temperature, simple-cubic form of polonium,²⁰⁴ all six interactions (the two shorter ones and the four longer ones; *cf.* Se and Te, Table VII) are equivalent. Their length, 3.34 Å, is within 8% of

(204) J. M. Goode, *J. Chem. Phys.*, 26, 1269 (1957).

the length estimated⁷⁰ for a polonium-polonium single bond (based upon $r(\text{Po}^{6+}) = 0.67 \text{ \AA}$).

The electronic structures of the next-nearest-neighbor interactions in the crystallized elements of groups V, VI, and VII may be viewed as electron donor-acceptor interactions. The halogens have been discussed from this point of view already (section II.B.2b);^{204a} protruding, unshared electrons in one molecule fit into the hollows of adjacent molecules. Similarly, in arsenic, antimony, and bismuth, the bumps of one "molecule"—an infinite puckered layer (Figure 47)—fit into the hollows of adjacent "molecules." This mode of packing places the lone pair on an atom near the backsides of three single bonds. The interaction may be viewed as a multicenter pair-pocket bond.

These postulated multicenter *intermolecular* interactions in crystalline arsenic, antimony and bismuth are formally analogous to the postulated multicenter *intramolecular* interactions in the boron hydrides. The boron hydrides have more atomic valence-shell orbitals than valence-shell electrons. Hence, if each valence-shell orbital is to be utilized in an intramolecular interaction, the valence-shell electrons must be shared by more than two atoms. With regard to the formation of two-center, intramolecular bonds, the compounds are electron deficient.⁶⁶ Similarly, the molecules in arsenic, antimony, and bismuth have more acceptor sites (pockets, hollows, antibonding orbitals) than donor sites (lone pairs). Hence, if each acceptor site is to be utilized in an intermolecular interaction, the lone pairs must be shared more than once. With regard to the formation of two-center, intermolecular bonds, crystalline arsenic, antimony, and bismuth are lone-pair deficient.

In As, Sb, and Bi, the valence electrons that participate in multicenter molecular interactions are bound less strongly by atomic cores than those that participate in two-center intramolecular interactions. An atom in these crystals, Bragg has remarked,²⁰⁵ behaves as a metal on one side and a nonmetal on the other.

Antimony is formally isoelectronic²⁰⁶ with tin telluride, SnTe, which has the sodium chloride structure. This structure can be obtained from the antimony structure by supposing that (1) the atoms on one side of a puckered Sb layer have become tellurium atoms and those on the other side tin; that (2) the tin atoms' lone pairs, which in antimony probably already are angularly more dispersed about their atomic cores than are the bonding pairs,²⁰⁷⁻²⁰⁹ have completely enveloped their

cores and become "inert" s-type electrons, thereby converting the Sn⁴⁺ cores to Sn²⁺ cores (decreasing the positive charge on an atom increases the relative stability of s-type orbitals); and that (3) the two spin-sets in the valence shell of a Te atom (four electrons of one spin and four of the other) are angularly anti-coincident.^{210,211} In this model of SnTe, which applies also to sodium chloride, each atom is bound to its neighbor by one two-center, one-electron bond and by one four-center, one-electron bond. The length calculated⁷⁰ for a two-center, two-electron bond between a Sn²⁺ core ($r = 0.93 \text{ \AA}$) and a Te⁶⁺ core ($r = 0.56 \text{ \AA}$) is 3.14 \AA ; the observed internuclear distance in SnTe is 3.16 \AA .²¹²

In the crystalline forms of selenium and tellurium that contain infinite chains (Figure 47), each atom may be viewed as forming two relatively strong and short, two-center, Lewis-type, intrachain, electron-pair bonds, in which the bonding electrons are shared equally by two atoms, and four weaker and longer, two-center, Hassel-type, interchain, electron-pair bonds, in which the bonding electrons are shared unequally by two atoms. In two of its interchain bonds a selenium or tellurium atom acts as a donor of electron pairs. In its other two interchain interactions it acts as an acceptor of electron pairs, in a manner similar to the sulfur atoms in sulfur dicyanide (Figure 19) and the tellurium atoms in square-planar complexes of Te(II).^{213,214} Owing to these acceptor interactions, the atoms' octets are somewhat expanded. In passing from sulfur through selenium and tellurium to polonium, the electron-pair coordination numbers of the atomic cores gradually increase, from four in sulfur to six in polonium. As with heteropolar compounds, an increase in coordination number can be effected by an increase in the size of the cations (here the M⁶⁺ cores of the group VI elements; the anions are the bonding electron pairs) or by an increase in pressure. Sulfur, at high pressures, has the hexagonal selenium structure²¹⁵ and tellurium, at 115 kbars, has the β -polonium structure: each tellurium atom has six nearest neighbors, at 3.00 \AA .²¹⁶ A simple cubic form of tellurium has been produced, also, by rapid quenching of gold-tellurium and silver-tellurium alloys.²¹⁷

In many hydrogen-bonded crystals, each molecule uses all of its acidic protons, *i.e.*, its best, *i.e.* (energet-

(204a) NOTE ADDED IN PROOF—See also, I. H. Hiller and S. A. Rice, *J. Chem. Phys.*, **46**, 3881 (1967).

(205) W. H. Bragg, *Nature*, **110**, 116 (1922).

(206) H. A. Bent, *J. Chem. Educ.*, **43**, 170 (1966).

(207) H. A. Bent, *ibid.*, **42**, 302 (1965).

(208) R. J. Gillespie, *ibid.*, **40**, 295 (1963).

(209) R. J. Gillespie and R. S. Nyholm, *Quart. Rev. (London)*, **11**, 339 (1957).

(210) J. W. Linnett, *J. Am. Chem. Soc.*, **83**, 2643 (1961).

(211) J. W. Linnett, "The Electronic Structure of Molecules. A New Approach," John Wiley and Sons, Inc., New York, N. Y., 1964.

(212) E. Parthé, "Crystal Chemistry of Tetrahedral Structures,"

Gordon and Breach, New York, N. Y., 1964.

(213) O. Foss, *Acta Chem. Scand.*, **16**, 779 (1962).

(214) O. Foss, *ibid.*, **17**, 1806 (1963).

(215) S. Geller, *Science*, **152**, 644 (1966).

(216) J. C. Jamieson and D. B. McWhan, *J. Chem. Phys.*, **43**, 1149 (1965).

(217) H. Luo and W. Klement, Jr., *ibid.*, **36**, 1870 (1962)

TABLE VIII
 CATION AND ANION COORDINATION NUMBERS IN OXIDES OF GROUPS IV, V, AND VI

| Oxide | Structure ^{111,113} | Cation's coordn no. | Anion's coordn no. |
|--------------------------------|--|---------------------|--------------------|
| CO ₂ | Triatomic molecule | 2 | 1 |
| SiO ₂ | Quartz | 4 | 2 |
| GeO ₂ | Quartz | 4 | 2 |
| SnO ₂ | Rutile | 6 | 3 |
| PbO ₂ | Rutile | 6 | 3 |
| N ₂ O ₃ | Pentatomic molecule (ONONO) ²²⁰ | 2 | 1 |
| P ₂ O ₃ | Molecular solid, P ₄ O ₆ | 3 | 2 |
| As ₂ O ₃ | Molecular solid, As ₄ O ₆ ²²¹ | 3+ | 12+ |
| Sb ₂ O ₃ | Molecular solid, Sb ₄ O ₆ ²²¹ | 3+ | 12+ |
| Bi ₂ O ₃ | Ionic solid | 6 | 4 |
| SO ₂ | Triatomic molecule | 2 | 1 |
| SeO ₂ | Infinite chains | 3 | 1, 2 |
| TeO ₂ | Distorted rutile ²²² | 4+ | 2+ |
| PoO ₂ | Fluorite | 8 | 4 |

 TABLE IX
 CALCULATED AND OBSERVED INTERATOMIC DISTANCES IN THE TRIOXIDES OF As, Sb, AND Bi

| Oxide | Shortest M-O distance, ^{112,221} | | Calcd M ³⁺ core | Next-shortest M-O distance in crystal (D ₂) | van der Waals distance (vwd) | | D ₂ - D ₁ | D ₁ - D ₁ |
|--------------------------------|---|---------------------------|----------------------------|---|------------------------------|----------------------|---------------------------------|---------------------------------|
| | Gas | Crystal (D ₁) | | | M ³⁺ core | M ³⁺ core | | |
| As ₂ O ₃ | 1.80 ± 0.05 (3) | 2.01 (3) | 1.84 | 1.96 | 2.78 (3) | 3.40 | 0.68 | 0.77 |
| Sb ₂ O ₃ | 2.0 ± 0.05 (3) | 2.22 (3) | 1.99 | 2.13 | 2.61 (3) | 3.60 | 0.99 | 0.39 |
| Bi ₂ O ₃ | | 2.40 (6) | 2.11 | 2.30 | (2.40) | (3.9) | (1.5) | 0 |
| (1) | (2) | (3) | (4) | (5) | (6) | (7) | (8) | (9) |

ically), its lowest lying acceptor sites, in the formation of intermolecular electron-pair donor-acceptor bonds. Similarly, in the face-centered bonded crystals of arsenic, antimony, bismuth, selenium, tellurium, chlorine, bromine, and iodine, each molecule (a puckered layer, a helical chain, or a simple dimer) uses all of its acidic "pockets" in the formation of intermolecular electron-pair donor-acceptor bonds. These statements are extensions of the rule that, in both covalently bonded⁶⁶ and ionically bonded²¹⁸ molecules, each atom uses all of its low-lying valence-shell orbitals in the formation of chemical bonds. Like an atom, a molecule is not electronically saturated unless all of its low-lying orbitals are occupied.

2. Oxides of Groups IV, V, and VI

In crystals of the elements in a given group of the periodic table the number of electrons in an atom's valence shell tends to increase as one moves down the group toward elements of higher atomic number (Table VII and the discussion pertaining thereto). A similar trend, well known for heteropolar compounds,²¹⁹ is illustrated for some oxides of the elements in groups IV, V, and VI, in Table VIII.²²⁰⁻²²² As the size of the cations increases, the number of anions about each cation tends to increase. Particularly instructive are the interatomic distances in the trioxides of arsenic, antimony, and bismuth.

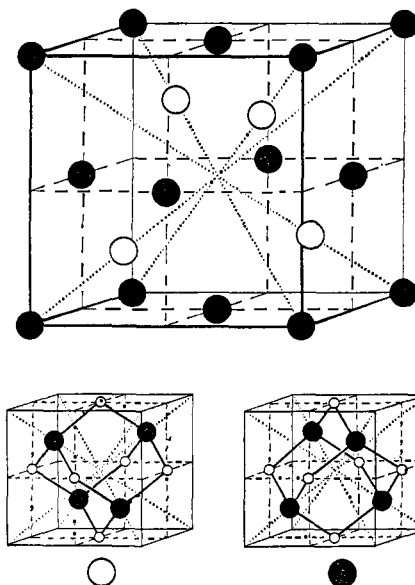

Figure 48.—Crystal structures of As₄O₆ and Sb₄O₆. Large open circles give the location of As₄O₆ or Sb₄O₆ units oriented as shown at the bottom left; large filled circles give the location of As₄O₆ and Sb₄O₆ units oriented as shown at the bottom right.

In the gaseous state the trioxides of arsenic and antimony consist of the molecules As₄O₆ and Sb₄O₆. These molecules persist in the solid state, where they are arranged in the same way as the carbon atoms in diamond, each molecule corresponding to one carbon atom²²¹ (Figure 48). This arrangement places each metal atom near three oxygen atoms in adjacent molecules. In the gaseous state the shortest metal-oxygen distances (Table IX, column 2) are close to the values calculated⁷⁰ for normal two-electron bonds between O⁶⁺ cores and the corresponding M⁵⁺ cores

(218) R. T. Sanderson, *J. Chem. Educ.*, **41**, 361 (1964).

(219) V. M. Goldschmidt, *Trans. Faraday Soc.*, **25**, 253 (1929).

(220) W. G. Fatley, H. A. Bent, and B. Crawford, Jr., *J. Chem. Phys.*, **31**, 204 (1959).

(221) R. M. Bozorth, *J. Am. Chem. Soc.*, **45**, 1621 (1923).

(222) L. N. Swink and G. B. Carpenter, *Acta Cryst.*, **21**, 578 (1966).

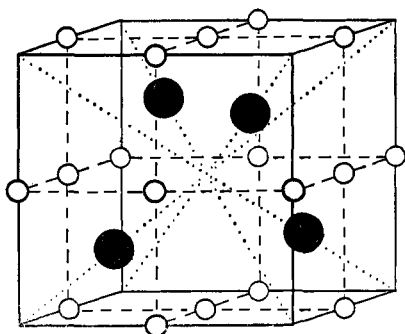

Figure 49.—Crystal structure of Bi_2O_3 ; cf. Figure 48: large filled circles, bismuths; smaller open circle, oxygen atoms.

(column 4). The shortest metal–oxygen distances in the solid state (column 3) are closer to the values calculated for normal two-electron bonds between O^{6+} and M^{3+} cores (column 5). The next-shortest metal–oxygen distances in the solid state (column 6) are significantly shorter than the corresponding van der Waals distances (column 7). The shortening (van der Waals distance) – (second-shortest M–O distance), increases with increasing atomic number (column 8). Correspondingly, the difference between the shortest and second-shortest M–O distances decreases with increasing atomic number (column 9), until in Bi_2O_3 the difference between primary and secondary metal–oxygen interactions vanishes (Figure 49).

As a general rule, in moving down a given group in the periodic table, the number of negatively charged particles—electrons or conventional anions—in the near-neighborhood of the atoms' cores tends to increase, both in the pure elements (Table VII) and in their compounds (Table VIII).

3. Selenious Acid, Iodic Acid, and Xenon Trioxide

Solid-state interactions similar to those in arsenic and antimony trioxide occur in crystals of H_2SeO_3 , HIO_3 , and XeO_3 , whose heavy atoms, Se, I, and Xe, like the heavy atoms in As_4O_6 and Sb_4O_6 , are bound pyramidally to three oxygen atoms and have one unshared pair.

In crystalline iodic acid each pyramidal IO_3 group (I–O distances, 1.78–1.92 Å; calculated single-bond distance, 1.87 Å) has about it three oxygen atoms from neighboring molecules in positions approximately opposite the three primary iodine–oxygen bonds²²³ (I···O distances, 2.50–2.87 Å;²²⁴ van der Waals distance, 3.55 Å). Similar interactions have been observed in ceric iodate monohydrate: each iodine atom has three oxygen neighbors at 1.77–1.86 Å and three others at 2.5–3.1 Å; together the oxygen atoms

form a much distorted octahedron about the iodine atom.²²⁵ Short, secondary I···O interactions occur also in anhydrous $\text{Ce}(\text{IO}_3)_4$ ²²⁶ and $\text{Zr}(\text{IO}_3)_4$.²²⁷ In aqueous solutions the IO_3^- ion appears to be strongly hydrated; its apparent molar volume, for example, is less than that of BrO_3^- and its solutions are surprisingly viscous.

The crystal structure of xenon trioxide is very similar to that of iodic acid.²²⁴ Each pyramidal XeO_3 molecule (Xe–O distances, 1.74–1.77 Å; estimated single bond distance, 1.81 Å) has about it three oxygen atoms from neighboring molecules, at 2.80–2.90 Å.²²⁴ Similarly, in the orthorhombic form of H_2SeO_3 each Se atom has in addition to its three nearest oxygen neighbors (mean Se–O distance, 1.74 Å; estimated single bond distance, 1.79 Å) three oxygen neighbors at 3.00–3.09 Å (vwd = 3.40 Å), which complete a distorted octahedral coordination group about the Se atom.²²⁸

In summary, it would appear that the local electronic environments of the selenium atoms in H_2SeO_3 , of the iodine atoms in HIO_3 , and of the xenon atoms in XeO_3 are similar to the electronic environments of the "half-metal" atoms in $\text{As}(\text{c})$, $\text{Sb}(\text{c})$, $\text{As}_4\text{O}_6(\text{c})$, $\text{Sb}_4\text{O}_6(\text{c})$, and (it may be added) to the electronic environment of the antimony atoms in $\text{SbF}_3(\text{c})$ ²²⁹ and in the molecular adduct $\text{SbI}_3 \cdot 3\text{S}_8$.⁵¹

G. LAYER STRUCTURES

1. Metal Halides, Chalcogenides, and Hydroxides

Over 70 compounds of the type MX_2 (M a metal, X a nonmetal) are known to be composed of infinite, layer-like molecules¹¹ (Figure 50). The coordination numbers of the metal and nonmetal atoms in these two-dimensional molecules are, like the coordination numbers of the three-dimensional rutile structure, six and three, respectively. In the rutile structure, however, the nonmetal atoms cannot easily expand their octets. An iodine or tellurium atom in such a structure would be coordinatively unsaturated; it would have only eight electrons in its valence shell. In the layer structure, however, the bumps of one molecule fit into the hollows of another. This mode of packing places nonmetal atoms with their unshared electrons next to other nonmetal atoms. In the layer structure the nonmetal atoms have more than eight electrons in the near-neighborhood of their valence shells. Such structures are formed by many divalent metal iodides, bromides, and chlorides, but not by their fluorides, and by several tetravalent metal tellurides, selenides, and sulfides, but not by their oxides.

(223) M. T. Rogers and L. Helmholtz, *J. Am. Chem. Soc.*, **63**, 278 (1941).

(224) D. H. Templeton, A. Zalkin, J. D. Forrester, and S. M. Williamson in "Noble Gas Compounds," H. H. Hyman, Ed., University of Chicago Press, Chicago, Ill., 1963, p 229.

(225) J. A. Ibers, *Acta Cryst.*, **9**, 225 (1956).

(226) A. C. Larson and D. T. Cromer, *ibid.*, **14**, 128 (1961).

(227) D. T. Cromer and A. C. Larson, *ibid.*, **9**, 1015 (1956).

(228) A. F. Wells, *ibid.*, **2**, 128 (1949).

(229) R. W. G. Wyckoff, "Crystal Structures," Vol. 2, 2nd ed., Interscience Publishers, New York, N. Y., 1964

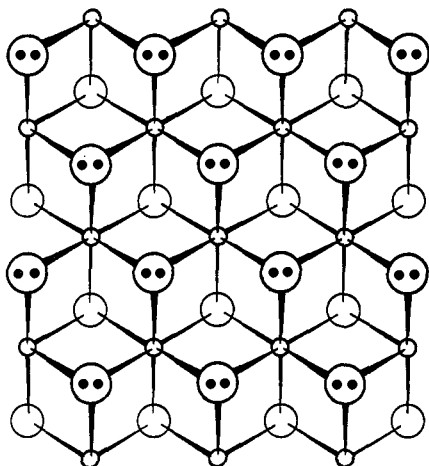

Figure 50.—Structure of the layer-like molecules in many metal halides, chalcogenides, and hydroxides of the type MX_2 : small open circles, metal atoms; large circles, nonmetal atoms; filled circles, unshared or protonated electrons.

Layer structures are formed also by many divalent metal hydroxides.¹¹¹ The anions in these compounds, like the anions in the corresponding compounds of the heavier halogens, are coordinatively saturated through intermolecular anion-anion electron donor-acceptor interactions, that is to say, through hydrogen bonding between adjacent layers. In the rutile structure, by contrast, the OH groups could not easily hydrogen bond to each other. In the rutile structure the OH groups would be coordinatively unsaturated.

In these layer structures one sees exhibited, again, an analogy between the structural chemistry of the three heavier halogens, I, Br, and Cl, and that of the pseudo-halogen OH. All four substituents are univalent and, for the analogy, equally important, amphoteric. In intermolecular interactions they act both as donors and acceptors of electrons.

2. Tetragonal Lead Monoxide and the Inert Pair

The layer structure of tetragonal lead monoxide²³⁰ has long been a puzzle.²³¹ Unlike the (nonmetal)-(metal)-(nonmetal) triple layers in the MX_2 structures discussed above (Figure 50), the triple layers of tetragonal PbO have their metal atoms on the outside (Figure 51). Within a triple layer the oxygen atoms lie in a plane sandwiched between two less densely populated planes of lead atoms. Each oxygen atom is surrounded tetrahedrally by four lead atoms, two from the plane of lead atoms on one side of the oxygen plane and two from the plane of lead atoms on the other side. Each lead atom is adjacent to four oxygen atoms, which form a square to one side of it. The

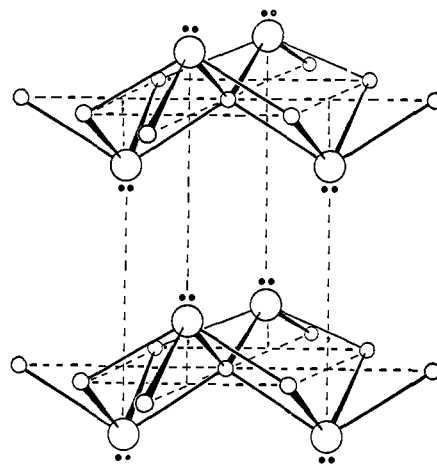
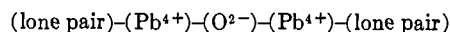

Figure 51.—Intermolecular interactions in tetragonal lead monoxide (after Wells¹¹³): small open circles, oxygen; large open circles, lead.

triple layers are packed in such a way that the bumps in one layer, produced by the protruding lead atoms, point toward the hollows in adjacent layers. Each lead atom has two lead neighbors from adjacent layers at 180° .

These facts suggest that a lead atom has in its valence shell on the side away from its four oxygen atoms a localized lone pair that points toward a lead atom in an adjacent layer.¹¹³ In this view, the atomic cores of the lead atoms in tetragonal PbO should be described as Pb^{4+} cores, not Pb^{2+} cores (Pb^{4+} cores completely surrounded by 6s electron pairs). The triple layers (lead)-(oxygen)-(lead) might better be formulated as



In this formulation a lead atom has in its *primary* valence shell five electron pairs, at the corners of a tetragonal pyramid. Four of the pairs about a Pb^{4+} core are shared with O^{6+} cores. Because a Pb^{4+} core is much larger than an O^{6+} core ($r_{Pb^{4+}} = 0.84 \text{ \AA}$, $r_{O^{6+}} = 0.09 \text{ \AA}$), these shared pairs lie much closer to the oxygen nuclei than they do to the lead nucleus; *i.e.*, the $Pb^{4+}-O^{6+}$ bonds are "ionic." The fifth pair about a Pb^{4+} core, the "lone pair," participates in an interlayer pair-pocket interaction with a Pb^{4+} core in an adjacent layer. Altogether, therefore, a Pb^{4+} core has in, or near, its valence shell approximately six pairs, five from its own layer and one from an adjacent layer. Observed interatomic distances support this formulation of tetragonal PbO.

The lead-oxygen distance in PbO is 2.30 \AA . The length calculated for a shared electron-pair bond between an O^{6+} core and a Pb^{4+} core is 2.21 \AA ; that calculated for an electron-pair bond between an O^{6+} core and a Pb^{2+} core is 2.57 \AA . As expected for a donor-acceptor interaction involving a large acceptor atom such as lead, the interlayer lead-lead distance in PbO

(230) W. J. Moore and L. Pauling, *J. Am. Chem. Soc.*, **63**, 1392 (1941).

(231) L. Pauling in "Fifty Years of X-Ray Diffraction," P. P. Ewald, Ed., International Union of Crystallography, Utrecht, Netherlands, 1962, p 139.

is only slightly longer than the length calculated for a normal electron-pair bond between the corresponding atomic cores. The observed lead-lead distance in PbO is 3.67 Å; the calculated length of a Pb⁴⁺-Pb⁴⁺ bond is 3.56 Å. The difference is about 0.1 Å. In tetragonal tin monoxide, the corresponding difference is 0.9 Å.

With ligands that are better leaving groups than oxide ions are, *e.g.*, with the ligands S²⁻, Se²⁻, and Te²⁻, the lone pair associated with the atomic cores of a group IVb element may squeeze between the ligands and the metal atom's core, particularly if the metal core is relatively large and has, therefore, a relatively low affinity for the ligands' electrons. In the limit, the lone pair completely envelops the core and becomes an "inert pair." Metal-metal interactions disappear, metal-ligand distances increase (over what they would have been had the unshared pair remained localized in the metal atom's valence shell), and the atoms' coordination numbers increase. With lead the lone pair is "inert" in the monosulfide, selenide, and telluride; all have the rock-salt structure. With tin,²³² the lone pair remains somewhat localized in the sulfide and selenide; only the telluride has the rock-salt structure. With germanium, none of the monochalcogenides has the rock-salt structure at room temperature.

H. SOLID-STATE INTERACTIONS THAT MAY REFLECT THE PRESENCE OF ANTICOINCIDENT SPIN SETS

1. Introduction. Spatial Correlation of Electrons in Molecules

Two factors operate to keep electrons in molecules apart: coulombic repulsions and the exclusion effect. The latter excludes configurations in which electrons whose spins are parallel are at the same place at the same time: two electrons can share the same region of space, if their spins are opposed, but not three. This restriction is generally well represented, graphically, by the bond diagrams of classical structural theory. In these diagrams, each stroke or pair of dots represents two electrons, one of each spin. Significantly, these strokes and dot pairs *never overlap*.²³³ In modern bond diagrams, electrons whose spins are parallel are localized in different regions of space.

In orbital descriptions of electronic structure the spatial separation of parallel spins required by the exclusion principle is achieved through the use of antisymmetrized wave functions.^{194,195} Such functions vanish if electrons of the same spin are "put" (1) in the same orbital or (2) in the same place. The first property, without further specification, is without

physical significance since, owing to the indistinguishability of electrons, the component orbitals of a wave function can be written in many ways. The second property is obviously important. Its significance in structural chemistry can best be displayed by transforming the component orbitals of a wave function into spatially localized functions.²³⁴⁻²³⁷ Generally these localized molecular orbitals (LMO)²³⁸⁻²⁴¹ may be viewed as mathematical models of the strokes and dots of conventional bond diagrams.^{234,236,238-242} Double occupancy of an orbital by opposed spins corresponds to Lewis's assumption²⁰¹ that each valence stroke in a bond diagram represents two electrons.

It is well known, however, that the assumption of two electrons per orbital is unnecessarily restrictive.²⁴³⁻²⁴⁵ Coulombic repulsions between electrons allowed to share the same orbital are too large. Better energies are obtained in quantum mechanical calculations if different orbitals are used for electrons of different spin (DODS).²⁴⁵ The utility of this "split-orbital" method was first demonstrated in quantitative calculations on helium by Hylleraas²⁴⁶⁻²⁴⁸ and Eckart.²⁴⁹ Later the idea was applied to π -electron systems.^{245,250,251} Its general application to chemical systems has been developed by Linnett.^{210,211} The method promises to become a useful one in furthering our understanding of the *mutual disposition* of electrons in molecules. It may prove particularly useful in understanding the origin in complex systems of couplings between magnetic subsystems²⁵²—between protons in diamagnetic substances, for example, and between magnetic ions in ferro- and antiferro-magnetic substances.²⁵³

Linnett's use of different orbitals for electrons of different spin may be viewed as a refinement of classical structural theory, in which the van't Hoff-Lewis model

(234) J. Lennard-Jones, *Proc. Roy. Soc. (London)*, **A198**, 14 (1949).

(235) H. K. Zimmerman, Jr., and P. van Rysselberghe, *J. Chem. Phys.*, **17**, 598 (1949).

(236) J. E. Lennard-Jones, *ibid.*, **20**, 1024 (1952).

(237) R. Daudel, H. Brion, and S. Odier, *ibid.*, **23**, 553 (1955).

(238) C. Edmiston and K. Reudenberg, *Rev. Mod. Phys.*, **35**, 457 (1963).

(239) K. Ruedenberg, *Mod. Quantum Chem.*, **1**, 85 (1965).

(240) D. Peters, *J. Chem. Soc.*, 2003 (1963).

(241) D. Peters, *J. Chem. Phys.*, **43**, S115 (1965).

(242) A. C. Hurley, J. Lennard-Jones, and J. A. Pople, *Proc. Roy. Soc. (London)*, **A220**, 446 (1953).

(243) P. O. Lowdin, *Phys. Rev.*, **97**, 1509 (1955).

(244) G. W. Pratt, Jr., *ibid.*, **102**, 1303 (1956).

(245) P. O. Lowdin, *Advan. Chem. Phys.*, **2**, 207 (1959).

(246) E. A. Hylleraas, *Z. Physik.*, **54**, 347 (1929).

(247) L. Pauling and E. B. Wilson, "Introduction to Quantum Mechanics," McGraw-Hill Book Co., Inc., New York, N. Y., 1935, Chapter 8, Section 29c.

(248) C. C. J. Roothaan and A. W. Weiss, *Rev. Mod. Phys.*, **32**, 194 (1960).

(249) C. Eckart, *Phys. Rev.*, **36**, 878 (1930).

(250) M. J. S. Dewar and C. E. Wulfman, *J. Chem. Phys.*, **29**, 158 (1958).

(251) M. J. S. Dewar and N. L. Hojvat, *Proc. Roy. Soc. (London)*, **A264**, 431 (1961).

(252) J. C. Slater, *Phys. Rev.*, **82**, 538 (1951).

(253) J. B. Goodenough, "Magnetism and the Chemical Bond," Interscience Publishers, New York, N. Y., 1963.

(232) R. E. Rundle and D. H. Olson, *Inorg. Chem.*, **3**, 596 (1964).

(233) H. A. Bent, *J. Chem. Educ.*, **44**, 512 (1967).

of the tetrahedral atom is applied twice, once to each set of spins,²⁵⁴ with the assumption that, owing to coulombic repulsions between electrons of opposite spin, there may be a relatively large degree of spatial anti-coincidence between a molecule's two spin sets. Figure 52a, for example, would be viewed as a better representation of the mutual disposition of electrons in a bromine molecule than the conventional representation in Figure 52b (x and o in Figure 52a represent electrons of opposite spin). Similarly, in Linnett's view, Figure 53a is a better representation of a benzene molecule than Figure 53b (x and o in Figure 53a represent electrons of opposite spin). Likewise, Figure 54a is considered to be a better representation of an oxygen molecule than Figure 54b.

These refinements in the graphic formulas of Br_2 , C_6H_6 , and O_2 are based upon theoretical considerations; *i.e.*, they are based upon the empirical laws of physics, rather than those of structural chemistry. The question arises, "Are these refinements useful in interpreting, for example, the 'puzzling'⁷³ stereochemistry of the benzene-bromine complex?" Is there, in other words, crystallographic evidence in support of the view that the most probable disposition of the valence-shell electrons in, for example, Br_2 and benzene, is one in which the molecules' spin sets are angularly (if not, also, radially) anti-coincident, in the manner indicated in Figures 52a and 53a?

2. The Benzene-Halogen Molecule Interaction

Three donor-acceptor models might be considered for benzene-halogen molecule interactions of the type illustrated in Figure 16. The electron donor might be the benzene molecule, the halogen molecule, or both. Usually the electron donor is assumed to be benzene,⁷³ although benzene can act as an electron acceptor (the benzene radical anion is known, for example) and a halogen molecule can act as an electron donor (Figure 24).

The conventional model of the $\text{C}_6\text{H}_6\text{-X}_2$ interaction (C_6H_6 the electron donor, X_2 the electron acceptor) is consistent with the observation that the interaction lowers the stretching frequency of the X_2 molecule^{255,256} as does the interaction of X_2 with, for example, trimethylamine,²⁵⁷ which is almost certainly an electron donor, although admittedly trimethylamine is a non-aromatic σ -electron donor, whereas benzene, in interactions of the type shown in Figure 16, would appear to be acting as an aromatic π -electron donor, unless perhaps it is assumed that the electron cloud of benzene is dome shaped.²⁵⁸

(254) H. A. Bent, *Chemistry*, **40**, 8 (1967).
 (255) J. Collin and L. D'Or, *J. Chem. Phys.*, **23**, 397 (1955).
 (256) W. B. Pearson, R. E. Erickson, and R. E. Buckles, *ibid.*, **27**, 1221 (1957).
 (257) H. Yada, J. Tanaka, and S. Nagakura, *J. Mol. Spectry.*, **9**, 461 (1962).
 (258) E. Mack, Jr., *J. Am. Chem. Soc.*, **54**, 2141 (1932).

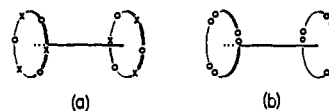

Figure 52.—Representations of the electronic structure of halogen molecules: (a) each unshared valence-shell electron is placed in its own spatial orbital; (b) each spatial orbital is occupied twice. In (a) x's represent electrons of one spin, o's electrons of the other spin. The straight lines represent bonding pairs.

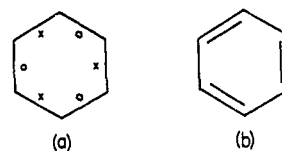

Figure 53.—Representations of the structure of benzene: (a) after Linnett; (b) after Kekulé.

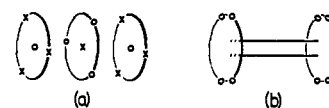

Figure 54.—Representations of the electronic structure of oxygen: (a) spin sets anti-coincident; (b) spin sets coincident.



Figure 55.—Model of the benzene-halogen molecule interaction in the solid state.

Usually it is assumed, however, that benzene's π cloud is more doughnut than dome shaped. But then the geometry of the benzene-halogen interaction in the solid state (Figure 16) is a puzzle,⁷³ if the customary assumption is made that in the ground states of the two molecules each occupied space orbital is doubly occupied. For, if there were two electrons of opposed spins in each occupied space orbital in each molecule, then in the region of the intermolecular interaction (Figure 16) the molecules would be building up electron spin density of the same sign in the same place, and, owing to the exclusion effect, the interaction should be repulsive, not attractive. If, however, the double-occupancy condition is relaxed, as indicated in Figures 52a and 53a, the electron clouds of the two molecules could merge slightly, as indicated by the dashed lines in Figure 55. In this model of the benzene-halogen molecule interaction, both molecules act as electron donors and acceptors.

From the viewpoint of the overlap of electronic wave functions, the interaction pictured in Figure 55 is formally analogous to the formation of a carbon-carbon bond by two methyl radicals. In the reaction $2\text{CH}_3\cdot = \text{H}_3\text{C-CH}_3$, each radical donates an electron to a vacant site in one of the spin sets of the other radical.

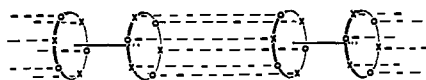

Figure 56.—Model of the iodine-iodine interaction in the starch-iodine complex.

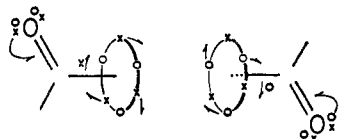

Figure 57.—Model of nearly linear C—hal...hal—C solid-state interactions.

3. The Starch-Iodine Complex and Related Interactions

The linear iodine-iodine and triiodide-triiodide chains postulated in models of the starch-iodine complex²⁵⁹ might be viewed as additional examples of the merging of the electron clouds of two molecules or ions whose spin sets are anticomponent (Figure 56).

Further examples of the role of anticomponent in intermolecular interactions may be the "polarization bonds" between substituted aromatic molecules²⁶⁰ and the nearly end-on C—hal...hal—C interactions discussed in section II.B.5 and illustrated in Figure 32b. Departures of the latter interactions from linearity might arise from incipient formation between the halogen atoms of two one-half-an-electron-pair-pocket interactions produced through electron shifts of the type indicated, for the case of the carbonyl compounds, by the curly barbs in Figure 57. These shifts may be viewed as the first steps of a cooperative elimination of a halogen molecule.

4. Solid-State Interactions in Oxygen and Fluorine

It has been reported that γ -O₂ and β -F₂ have ("surprisingly") the same structure type.²⁶¹ At the temperature of the X-ray studies (50°K), the structures are evidently orientationally disordered.²⁶¹ Hence, it is not possible to state definitely how the molecules interact in these solids. That they have the same structure type, however, is consistent with, if not required by, the view that in O₂ one spin set (the seven-membered spin set in Figure 54a) is similar to the two spin sets in F₂ (see Figure 52a).

The model of the electronic structure of O₂ in Figure 54 implies that the spin density in the molecule should be positive in doughnut-shaped regions about the molecular axis beyond each nucleus and negative in a similarly

shaped region between the nuclei. Now, exclusion effects between adjacent molecules in a crystal would be minimized, if, in regions of electronic overlap, the spin densities of the molecules were of opposite sign. For most, though not all, orientations of two molecules, this condition would be met if the net spins of the two molecules were of opposite sign. Thus, to minimize exclusion effects, the electron clouds of adjacent molecules should generally be coupled antiferromagnetically. Even if some ferromagnetic coupling exists, the over-all coupling in a crystal should be antiferromagnetic. And hence, as observed, the contribution per molecule to the magnetic susceptibility of the solid should be less than that of free O₂ molecules. In fact, it is very much less.^{262,263}

The infrared spectrum of solid oxygen provides further evidence that even for a simple nonpolar molecule like oxygen intermolecular interactions in condensed systems probably entail more than conventional van der Waals, zero-point energy effects.²⁶⁴ Unlike free O₂, solid oxygen absorbs infrared radiation at frequencies very near the fundamental frequency of free O₂.^{265,266} This unexpected observation implies that a change in internuclear distance in an oxygen molecule produces an asymmetric change in the local electronic environment of the nuclei. This conclusion is fully consistent with the supposition that, in the solid state, there may be significant overlap between the electron clouds of molecules whose spin sets are anticomponent. The spectrum of solid oxygen is, from this point of view, a special instance of the enhancement of an infrared absorption band by an "electron-vibration" mechanism.²⁶⁷

5. Short Hydrogen Bonds

Table X gives heavy-atom-heavy-atom distances X...Y in some selected hydrogen bonds X—H...Y. These distances have been determined by neutron diffraction,^{268,269} in most cases they are believed to be accurate to 0.02 Å, or better. More extensive, but generally older and less accurate, data on interatomic distances in hydrogen bonds have been summarized by Pimentel and McClellan.¹⁴⁸ The data cited in Table X support the following generalizations.

(262) W. F. Giaque and H. L. Johnston, *J. Am. Chem. Soc.*, **51**, 2300 (1929).

(263) W. H. Lien and N. E. Phillips, *J. Chem. Phys.*, **34**, 1073 (1961).

(264) B. Chu, "Molecular Forces. Based on the Baker Lectures of Peter J. W. Debye," Interscience Publishers, New York, N. Y., 1967, Chapter 3, Section 5.

(265) R. V. St. Louis and B. Crawford, Jr., *J. Chem. Phys.*, **37**, 2156 (1962).

(266) B. R. Cairns and G. C. Pimentel, *ibid.*, **43**, 3432 (1965).

(267) E. E. Ferguson and F. A. Matsen, *J. Am. Chem. Soc.*, **82**, 3268 (1960).

(268) G. E. Bacon, "Applications of Neutron Diffraction in Chemistry," The Macmillan Co., New York, N. Y., 1963.

(269) W. C. Hamilton, *Ann. Rev. Phys. Chem.*, **13**, 22 (1962).

(259) J. M. Reddy, K. Knox, and M. B. Robin, *J. Chem. Phys.*, **40**, 1082 (1964).

(260) S. C. Wallwork, *J. Chem. Soc.*, 495 (1961).

(261) T. H. Jordan, W. E. Strieb, H. W. Smith, and W. N. Lipscomb, *Acta Cryst.*, **17**, 777 (1964).

TABLE X
DISTANCES X...Y IN HYDROGEN BONDS X—H...Y^a

| No. | Compound | Distance, ^{a,b} Å |
|----------------|--|----------------------------|
| O—H...O Bonds | | |
| 1 | Acetamide·0.5HCl | 2.42 ^b |
| 2 | KH maleate | 2.44 ^b |
| 3 | KH ₂ PO ₄ | 2.487 |
| 4 | NaHCO ₃ ·Na ₂ CO ₃ ·2H ₂ O | 2.50 ^b |
| 5 | Oxalic acid dihydrate | 2.52 |
| 6 | KH ₂ AsO ₄ | 2.52 |
| 7 | KH bis(phenyl acetate) | 2.54 ^b |
| 8 | AlOOH | 2.650 |
| 9 | α-HIO ₃ | 2.69 |
| 10 | α-Resorcinol | 2.72 |
| 11 | Pentaerythritol | 2.74 |
| 12 | H ₂ O | 2.76 |
| 13 | H ₂ O ₂ | 2.798 |
| 14 | CaSO ₄ ·2H ₂ O | 2.82 |
| 15 | Oxalic acid dihydrate | 2.84 |
| O—H...F Bonds | | |
| 16 | FeSiF ₆ ·6H ₂ O | 2.70 |
| 17 | CuF ₂ ·2H ₂ O | 2.715 |
| O—H...Cl Bonds | | |
| 18 | NH ₂ OH·HCl | 3.04 |
| 19 | CuCl ₂ ·2H ₂ O | 3.18 |
| N—H...O Bonds | | |
| 20 | NH ₄ H ₂ PO ₄ | 2.91 |
| 21 | Sulfamic acid | 2.97 |
| 22 | N-Acetylglycine | 3.03 |
| 23 | Urea | 3.034 |
| F—H...F Bonds | | |
| 24 | KHF ₂ | 2.26 ^b |
| 25 | KH ₂ F ₃ | 2.33 |
| 26 | HF (solid) | 2.49 |

^a Determined by neutron diffraction. ^b Probably symmetric.

(1) There are two types of O—H...O bonds: short ones, length 2.42–2.54 Å (no. 1–7); and long ones, length 2.72–2.84 Å (no. 10–15). Presumably these differences in interatomic distances, on the average about 0.30 Å, reflect differences in the electronic structures of the interatomic linkages.¹¹³

(2) Short hydrogen bonds often are probably symmetric (no. 1, 2, 4, 6, and 24).

(3) Short hydrogen bonds often are associated with a center of symmetry in the crystal, such that the transfer of the proton from one ligand to the other creates an equivalent bonding situation.²⁶⁹

(4) Long O—H...O bonds involve one (or two) oxygen atom(s) to which there would be, in the absence of the hydrogen bond, two single, covalent bonds (phenols, alcohols, hydrogen peroxide, ice, and hydrates; no. 10–15).

(5) O—H...O bonds of intermediate length, say ~2.65 Å (no. 8 and 9), appear to involve oxygen atoms that are bound to noble gas or d¹⁰ atomic cores of intermediate size ($r_{A^{18+}} = r_{T^{10+}} = 0.50$ Å).

(6) N—H...O bonds (no. 20–23) show less variation in length than O—H...O bonds.

(7) There appear to be no "short" N—H...O (or N—H...N^{148,270}) bonds. (Exceptions may be the

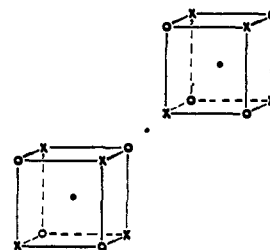

Figure 58.—Model of the linear, symmetrical HF₂⁻ ion. x's represent electrons of one spin, o's electrons of the other spin. Small filled circles represent atomic cores of F and H atoms.

2.57-Å intramolecular N—H...ONO bond in nitroguanidine²⁷¹ and the 2.63-Å N—H...O=C bond in the urea-hydrogen peroxide adduct.²⁷²)

(8) RO—H...B bonds are relatively constant in length for a given ligand atom B if the atom in the substituent R to which the oxygen atom is attached has a small core (C⁴⁺ in no. 10 and 11; H⁺ in no. 12, 14–16, and 19; O⁶⁺ in no. 13; and N⁵⁺ in no. 18).

(9) F—H...F bonds, like O—H...O bonds, show considerable variation in length (no. 24–26).

(10) The shortest F—H...F bond, like several of the short O—H...O bonds, is probably symmetric.

(11) The variation in the length of F—H...F bonds (~0.23 Å), although smaller, is comparable in magnitude (and perhaps in origin) to the variation in the length of O—H...O bonds, particularly if allowance is made for the difference in the sizes of fluorine and oxygen atoms.

(12) Nitrogen atoms do not participate in symmetric hydrogen bonds.

These generalizations are consistent with the view that, from the standpoint of the exclusion effect, a relatively short intermolecular contact between two atoms can occur if the spin sets in the valence shells of *each* atom can be, to some extent, anticoincident. Linnett's model of HF₂^{-201,211} illustrates this point (Figure 58). The representation of the symmetrical F...H...F interaction in Figure 58 may be described as two partially merged, protonated, one-electron-pocket bonds.²⁰⁷

Anticoincidence can occur, also, about oxygen atoms bound to second- and later-row elements, such as phosphorus and arsenic²¹¹ (no. 3 and 6), as well as in systems that, according to Pauling,⁷ are resonance stabilized, such as the carbonate ion, amides, carboxylic acids, and the anions of carboxylic acids (no. 1, 2, 4, 5, and 7).

Structurally significant amounts of anticoincidence are generally not expected to occur, in the absence of "resonance effects," in the valence shells of atoms that share electrons with two or more small-core atoms

(271) J. H. Bryden, L. A. Burkardt, E. W. Hughes, and J. Donohue, *Acta Cryst.*, **9**, 573 (1956).

(272) C. S. Lu, E. W. Hughes, and P. A. Giguère, *J. Am. Chem. Soc.*, **63**, 1507 (1941)

(270) J. Donohue, *J. Phys. Chem.*, **56**, 502 (1952).

($r_{\text{atomic core}} < 0.15 \text{ \AA}$). Included in this category are the oxygen atoms in alcohols, hydrogen peroxide, water, salt hydrates, and most, if not all, covalently bonded nitrogen atoms (no. 10–23).

The last three compounds in Table X form an interesting comparison. These compounds contain hydrogen-bonded chains of the general formula $(\text{H}_n\text{F}_{n+1})^-$; the index n is equal to 1 for HF_2^- (no. 24), 2 for H_2F_3^- (no. 25), and ∞ for solid HF (no. 26). If the spin sets of the fluorine atoms in these compounds were fully coincident, *i.e.*, if each fluorine atom contained in its valence shell four spatially coincident electron pairs, the angle $\text{F}\cdots\text{F}\cdots\text{F}$ in H_2F_3^- and in solid HF should be slightly less than the tetrahedral angle, say 105° . If, on the other hand, the spin sets about each fluorine atom were maximally anticoincident, as indicated in Figure 58, the $\text{F}\cdots\text{F}\cdots\text{F}$ angle should be 180° . The observed angles fall between these two extremes: 135° for H_2F_3^- ,²⁷³ 120° for solid HF.²⁷⁴ The hydrogen bonds are unsymmetrical in both KH_2F_3 ²⁷⁵ and solid HF.^{276, 277}

In the present model, a decrease in bond angle corresponds to an increase in spin-set coincidence, and, therefore, by the exclusion principle, to a decrease in permissible overlap between the electron clouds of adjacent atoms. In going from KH_2F_3 to solid HF, the $\text{F}\cdots\text{F}\cdots\text{F}$ angle decreases by 15° and the $\text{F}\cdots\text{F}$ distance does increase, by 0.16 \AA . At this rate, the length of a hydrogen bond between two fluorine atoms, one of which, at least, has its spin sets fully coincident in the bonding region, would be, by a linear extrapolation to an $\text{F}\cdots\text{F}\cdots\text{F}$ angle of 105° , 2.65 \AA . The length calculated from the corresponding tangent-sphere representation of the interaction²⁰⁷ is the same, 2.65 \AA . This figure represents the estimated length of a normal, "long" $\text{F}-\text{H}\cdots\text{F}$ bond. The estimated length of a normal, "short" (and probably symmetric) $\text{F}\cdots\text{H}\cdots\text{F}$ bond between two fluorine atoms, both of which have their spin sets maximally anticoincident (Figure 58), is, by a linear extrapolation to an $\text{F}\cdots\text{F}\cdots\text{F}$ angle of 180° , 1.85 \AA . The length calculated from the tangent-sphere representation of an $\text{F}\cdots\text{F}$ interaction with maximum overlap of anticoincident spin sets²⁰⁷ is 1.89 \AA . These results are summarized in Figure 59.

From Figure 59 and the observed $\text{F}\cdots\text{F}$ distance in KHF_2 , it is estimated that the spin sets about the fluorine atoms in the ion HF_2^- (in KHF_2) have achieved only about 50% of full anticoincidence. The data in Table X suggest that the spin sets about hydrogen-bonded oxygen atoms achieve even less anticoincidence

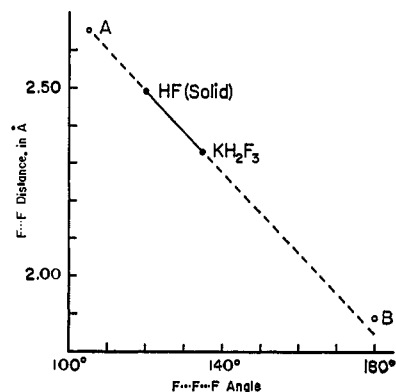

Figure 59.—Plot of the $\text{F}\cdots\text{F}$ distance and the $\text{F}\cdots\text{F}\cdots\text{F}$ angle in solid HF and KH_2F_3 : A = calculated value for fully coincident spin sets; B = calculated value for maximally anticoincident spin sets. It is assumed in the calculations that the hydrogen bonds are linear.

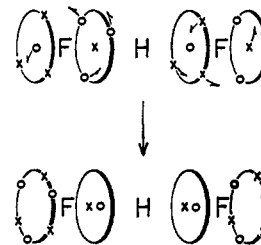

Figure 60.—Relation between coincident and anticoincident models of the $\text{F}\cdots\text{H}\cdots\text{F}$ interaction.

than do those about hydrogen-bonded fluorine atoms. The transition in HF_2^- from full anticoincidence, estimated $\text{F}\cdots\text{F}$ distance 1.88 \AA , to no anticoincidence in the bonding region, estimated $\text{F}\cdots\text{F}$ distance 2.65 \AA , is shown schematically in Figure 60.

Protons evidently have a powerful tendency to produce spatially coincident electron pairs, owing, presumably, to the fact that, unlike other atomic cores, they have no inner-shell electrons and, hence, can burrow into electron clouds and by their positive charges bring into partial or perhaps nearly complete coincidence the spin sets in atoms' valence shells. Were it not for this property, H_2O would be a linear molecule,²⁵⁴ as $\text{Li}_2\text{O}(\text{g})$ is reported to be.²⁷⁸ Full anticoincidence in the valence shell of oxygen and fluorine atoms is probably most likely to occur in oxides and fluorides of elements whose atoms, like lithium atoms, have relatively large atomic cores and, which, by virtue of this property, produce relative weak electric fields in the regions surrounding their atomic cores.

6. Bridging Oxygen and Fluorine Atoms

a. Evidence for expanded octets

How best to describe the bond between oxygen atoms and atoms with medium to large atomic cores ($r_{\text{core}} \gtrsim$

(273) J. D. Forrester, M. E. Senko, A. Zalkin, and D. H. Templeton, *Acta Cryst.*, **16**, 58 (1963).

(274) M. Atoji and W. N. Lipscomb, *ibid.*, **7**, 173 (1954).

(275) R. Blinc, Z. Trontelj, and B. Volavšek, *J. Chem. Phys.*, **44**, 1028 (1966).

(276) E. F. Westrum, Jr., and K. S. Pitzer, *J. Am. Chem. Soc.*, **71**, 1940 (1949).

(277) J. S. Waugh, F. B. Humphrey, and D. M. Yost, *J. Phys. Chem.*, **57**, 486 (1953).

(278) A. Büchler, J. L. Stauffer, W. Klemperer, and L. Wharton, *J. Chem. Phys.*, **39**, 2299 (1963).

0.25 Å) is one of the unsolved problems of valence theory.^{113,279,280} The sulfur-oxygen distances in SO₂ and SO₃, for example, are nearly identical (1.43 Å²⁸¹). They are, also, significantly shorter than the expected length⁷⁰ of a sulfur-oxygen single bond ($\lesssim 1.66$ Å). Similarly, bonds between oxygen and silicon, phosphorus, or chlorine atoms are generally shorter than estimated single-bond distances. Noteworthy, also, are the large bond angles at oxygen atoms that are bound to two "heavy" atoms. The data have been reviewed by Gillespie.^{282,283} The Cl-O-Cl angle in Cl₂O and the average values of the S-O-S, P-O-P, and Si-O-Si angles cited by Gillespie are 110.8, 118, 128, and 137°, respectively. This progressive opening of the valence angle at oxygen (and, it may be added, at nitrogen) atoms with increasing size of the atomic core of the attached atoms might conceivably be a steric effect between nonbonded atoms. There is evidence, however, to support the view that it is an electronic effect between directly bonded atoms—between oxygen (or nitrogen) atoms and silicon, phosphorus, sulfur, or chlorine atoms. For example, contrary to what would be expected from the inductive effect, silanols are weaker bases than the corresponding carbinols,²⁸⁴ (CH₃)₂PN(CH₃)₂ is a weaker base than (CH₃)₃N,²⁸⁵ organic sulfides are stronger acids than the corresponding ethers,²⁸⁶ and chloroform is a stronger acid than fluoroform.²⁸⁷ These facts are generally explained by supposing that there is some double-, multiple-, or π -bond character in bonds between oxygen (or nitrogen or fluorine) atoms and the "heavy" atoms silicon, phosphorus, sulfur, and chlorine. Without a mathematical analysis of the corresponding antisymmetrized wave function, however, these descriptions of the bonds generally do not give the mutual disposition of the electrons in such systems²⁸⁸ and, hence, as they stand, generally do not indicate what the stereochemistry of the residual affinities of the oxygen (or fluorine) atoms might be. Because it does purport to give the mutual disposition of electrons in chemical compounds, Linnett's refinement of classical structural theory^{210,211} is of some interest in this respect.

b. Electronic structure of the P-O bond

By way of illustration, consider the phosphorus-oxygen bond in a phosphine oxide, R₃PO. It is as-

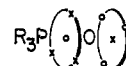

Figure 61.—Model of the P-O bond in phosphine oxides.

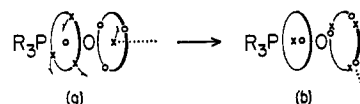

Figure 62.—Model of the relation between the order (and length) of the P-O bond in phosphine oxides and the bond angle at oxygen in intermolecular interactions; cf. Figure 15.

sumed that in this compound the electronegative oxygen atom has in the near-neighborhood of its atomic core eight valence-shell electrons, four of each spin arranged approximately tetrahedrally about the core. It is convenient, therefore, to view the P-O bond as formed from the union of an ion O²⁻ with the ion R₃P²⁺. At least six limiting possibilities may be considered. If the two spin sets in the O²⁻ ion were fully coincident in the compound R₃PO, the resulting tetrahedral-like O²⁻ charge distribution might be viewed as approaching the phosphorus atom (1) off a corner of the O²⁻ tetrahedron, (2) off an edge of the O²⁻ tetrahedron, or (3) off a face of the O²⁻ tetrahedron, forming thereby classical single, double, or triple bonds. If, on the other hand, the two spin sets in the O²⁻ ion were fully anti-coincident in R₃PO, the resulting cubical-like O²⁻ charge distribution might be viewed as approaching the phosphorus atom (4) off a corner of the O²⁻ cube, (5) off an edge of the O²⁻ cube, or (6) off a face of the O²⁻ cube. Possibility 5 corresponds to the formation of a "splayed single bond."²⁸⁹ Possibility 4, Linnett's choice,²¹¹ corresponds for one spin set to the formation of a single bond and for the other spin set to the formation of a triple bond displaced somewhat toward the oxygen atom's core; altogether, formulation 4 places in the P-O bonding region approximately four electrons (Figure 61).

c. Structural implications of anticoincidence about oxygen

Magnetically, a P-O (or S-O) bond of the type shown in Figure 61 should have some of the properties of a triple bond. Structurally, the oxygen atom of such a bond should be capable of acting as an electron donor in a direction directly along the axis of the P-O bond, and evidently does in the complex between triethyl phosphate and benzotrifuroxan.²⁹⁰

A Lewis acid capable of interacting effectively with a spatially coincident electron pair might be expected to force the spin sets about the oxygen atom of an electron-

(279) G. A. Barclay, E. G. Cox, and H. Lynton, *Chem. Ind.* (London), 178 (1956).

(280) P. J. Wheatley, *Ann. Rev. Phys. Chem.*, **8**, 383 (1957).

(281) L. E. Sutton, Ed., "Tables of Interatomic Distances and Configuration in Molecules and Ions," Special Publication No. 11, The Chemical Society, London, 1958.

(282) R. J. Gillespie, *J. Am. Chem. Soc.*, **82**, 5978 (1960).

(283) R. J. Gillespie, *Can. J. Chem.*, **39**, 318 (1961).

(284) R. West and R. H. Baney, *J. Am. Chem. Soc.*, **81**, 6145 (1959).

(285) A. B. Burg and P. J. Slota, Jr., *ibid.*, **80**, 1107 (1958).

(286) G. Cilento, *Chem. Rev.*, **60**, 147 (1960).

(287) J. Hine and S. J. Ehrenson, *J. Am. Chem. Soc.*, **80**, 824 (1958).

(288) O. Sinanoglu, *Advan. Chem. Phys.*, **6**, 315 (1964).

(289) H. A. Bent, *Inorg. Chem.*, **2**, 747 (1963).

(290) C. K. Prout and S. C. Wallwork, *Acta Cryst.*, **21**, 449 (1966).

donor molecule such as R_3PO into partial or perhaps nearly full coincidence (Figure 62). An increase in coincidence in the oxygen atom's valence shell should produce two observable effects: (i) it should decrease the bond angle at the oxygen atom (the angle $P-O\cdots$ in Figure 62) from 180° (Figure 62a) to approximately, in the limit of full coincidence, 109° (Figure 62b); and (ii) it should increase the length of the bond to the oxygen atom within the donor molecule, from a length appropriate to a (nearly) four-electron bond (Figure 62a) to a length appropriate, in the limit of full coincidence, to a two-electron bond (Figure 62b). The data cited by Lindqvist⁶⁹ for inorganic adduct molecules of oxo compounds (Table IV) conform fairly well to this pattern (Figure 15). In these adducts, the bond angle at oxygen is smallest, and the bond length to oxygen in the donor molecule is closest to a single-bond length (and coincidence in the oxygen atom's valence shell presumably is largest) for oxygen atoms that are bound to "heavy" atoms that have in their valence shells expandable²⁰⁹ lone pairs (Table IV, no. 9-13).

d. Unsymmetrical and symmetrical fluorine atom bridges

When bound to medium-to-large atomic cores, the "valence" angles of bridging fluorine atoms, like those of bridging oxygen atoms, are usually large. In crystalline silicon tetrafluoride, a molecular solid with a body-centered-cubic arrangement of SiF_4 molecules²²⁹ (which are isoelectronic²⁰⁶ with $(CH_3)_3PO$), each fluorine atom participates in one, and each silicon atom in eight, weak, highly unsymmetrical, linear $Si-F\cdots Si$ bridges (Figure 63). In zirconium tetrafluoride, the distinction between inter- and intramolecular interactions has essentially vanished: each zirconium atom has eight fluorine neighbors at distances between 2.03 and 2.18 Å (the calculated zirconium-fluorine single-bond distance is 2.11 Å⁷⁰), and each fluorine atom is in contact with two zirconium atoms.²²⁹

A symmetrical fluorine bridge occurs in the adduct $KF \cdot 2Al(C_2H_5)_3$, which contains linear $(C_2H_5)_3Al-F-Al(C_2H_5)_3$ anions; $Al-F$ distance, 1.82 Å²⁹¹ (calculated single-bond distance, 1.83 Å⁷⁰).

e. Antiferromagnetic coupling through anions

Collinear bonds at oxygen atoms have been reported for the species $[(C_2H_5)Cl_2Ti-O-TiCl_2(C_2H_5)]$,²⁹² $(Cl_5Ru-O-RuCl_5)^{4-}$,²⁹³ and $(Cl_5Re-O-ReCl_5)^{4-}$.²⁹⁴ Significantly, the latter two ions are essentially diamagnetic. Evidently the spins of the metal atoms in

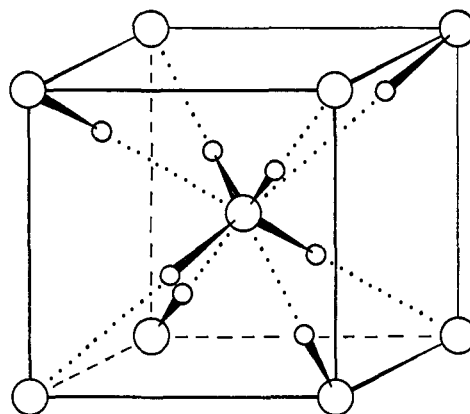

Figure 63.—Linear, unsymmetrical fluorine bridges in crystalline SiF_4 : small circles, fluorine; large circles, silicon.

these anions are coupled antiferromagnetically by the intervening oxygen atoms. This conclusion is consistent with the assumption that the spin sets in the valence shells of these bridging oxygen atoms are in an anticoincident configuration like, or similar to, that shown in Figure 61. In such a configuration the spin densities at one end of an oxygen atom are opposite in sign to those at the other end.^{294a}

Similar magnetic coupling schemes have been observed in several transition metal trifluorides²⁹⁵ that have the WO_3 structure¹¹³ with linear, or nearly linear, $M-F-M$ bridges. (In WO_3 itself the $W-O-W$ angles are 158° .²⁹⁶)

The first and best known example of antiferromagnetic coupling through linear cation-anion-cation bridges is MnO ²⁹⁷ (Figure 64). Of the 12 nearest manganese neighbors surrounding an $Mn(II)$ ion, six have their spins oriented parallel to that of the central ion and six have their spins oriented antiparallel, below $122^\circ K$.²⁹⁷ With this arrangement, any nearest neighbor manganese-manganese interactions will give the same contribution to the energy of the crystal as would a completely random distribution of spins; such interactions cannot, therefore, be the source of the ordering.²⁹⁸ On the other hand, the six next-nearest manganese neighbors to an $Mn(II)$ ion all have their spins aligned antiparallel to the central ion. Along the cube axes there is always antiferromagnetic coupling from one $Mn(II)$ ion to the next. This coupling acts through, and presumably is caused by, the intervening O^{2-} ions.²⁹⁹⁻³⁰¹ In general, the nature of the coupling,

(294a) NOTE ADDED IN PROOF.—A similar model has been proposed by V. Halpern, *Proc. Royal Soc. (London)*, **A291**, 113 (1966).
(295) E. O. Wollan, H. R. Child, W. C. Koehler, and M. K. Wilkinson, *Phys. Rev.*, **112**, 1132 (1959).

(296) B. O. Loopstra and P. Bolorini, *Acta Cryst.*, **21**, 158 (1966).

(297) C. G. Shull, W. A. Strauser, and E. O. Wollan, *Phys. Rev.*, **83**, 333 (1951).

(298) A. B. Lidiard, *Rept. Progr. Phys.*, **17**, 201 (1954).

(299) H. A. Kramers, *Physica*, **1**, 182 (1934).

(300) P. W. Anderson, *Phys. Rev.*, **79**, 350 (1950).

(301) Y. Li, *ibid.*, **102**, 1015 (1956).

(291) G. Allegra and G. Perogo, *Acta Cryst.*, **16**, 185 (1963).

(292) P. Corrandini and G. Allegra, *J. Am. Chem. Soc.*, **81**, 5510 (1959).

(293) A. M. Mathieson, D. P. Mellor, and N. C. Stephenson, *Acta Cryst.*, **5**, 185 (1952).

(294) J. C. Morrow, *ibid.*, **15**, 851 (1962).

whether it is ferro- or antiferromagnetic, depends upon the d-orbital occupancy of the magnetic cations. Empirical coupling schemes have been derived by several authors.³⁰¹⁻³⁰³ The extensive literature on magnetic solids has been reviewed by Goodenough.²⁵³

7. The Decaammine- μ -peroxo-dicobalt Cation

The two-spin sets of a molecule or ion that contains an odd number of electrons cannot be fully coincident at all points in space. The structure of the decaammine- μ -peroxo-dicobalt cation^{304,305} is interesting in this regard. The cobalt atoms in this peroxo-bridged dicobalt cation, $(\text{NH}_3)_5\text{CoO}_2\text{Co}(\text{NH}_3)_5^{5+}$, are octahedrally coordinated: each metal atom is surrounded by five ammonia molecules (Co-N distance 1.95 Å) and by one of the oxygen atoms of the bridging O_2 group (Co-O distance 1.90 Å). The two cobalt atoms and the two oxygen atoms of the peroxo bridge form an almost planar, zig-zag chain. The Co-O-O angles are 119°. The oxygen-oxygen distance in the bridging O_2 group is 1.31 Å, much shorter than the 1.48 Å found in the two-electron oxygen-oxygen bond in peroxides, much longer than the 1.20 Å found in the four-electron bond in molecular oxygen, but only slightly longer than the 1.28 Å found in the three-electron oxygen-oxygen bond in alkali metal superoxides. These facts suggest that the bridging O_2 group is a superoxide ion, O_2^- , that contains a three-electron oxygen-oxygen bond and shares, in σ -bonds, electron pairs with Co^{3+} ions³⁰⁵ (Figure 65).

III. INTRAMOLECULAR DONOR-ACCEPTOR INTERACTIONS

A. INTRODUCTION

Do donor-acceptor interactions occur within, as well as between, molecules?

Structural evidence for intermolecular donor-acceptor interactions rests upon the establishment of standard "contact" distances, with which other intermolecular distances in crystals may be compared. If the distance between two atoms in different molecules in a crystal is significantly less than the standard contact distance, *i.e.*, if the interatomic distance is noticeably less than the sum of the corresponding "van der Waals" radii, a specific interaction is indicated. Generally, probably always, such interactions can be interpreted as electron donor-acceptor interactions.

To apply this type of analysis to interatomic distances within molecules, it is necessary to have a set of standard "contact" distances—the single-, double-,

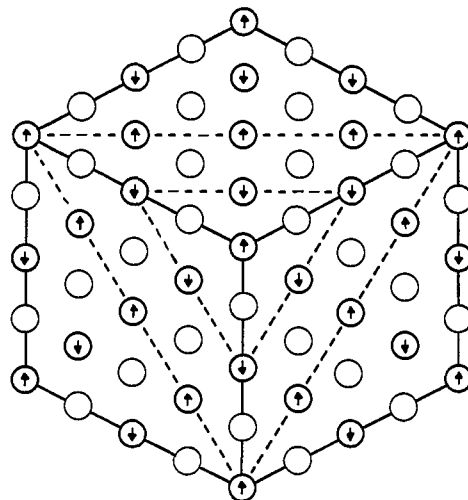

Figure 64.—Magnetic structure of MnO below its Néel temperature: heavy circles, manganese; light circles, oxygen.

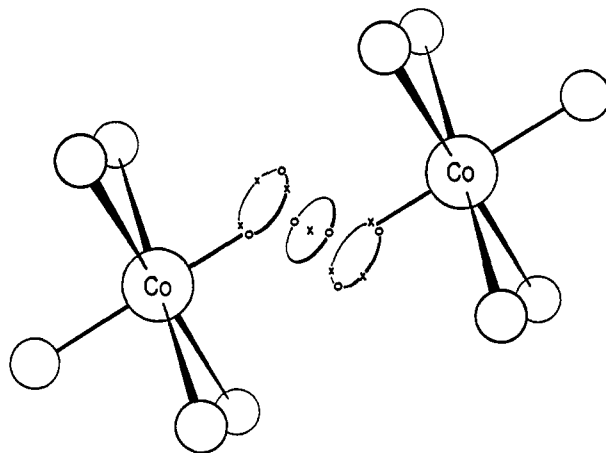

Figure 65.—Model of the peroxo bridge in $(\text{NH}_3)_5\text{CoO}_2\text{OC}(\text{NH}_3)_5^{5+}$.

and triple-bond radii given by Pauling,⁷ for example. In addition, it is necessary to consider how these standard contact distances, or reference "bond lengths," vary with the bond's environment. (A similar analysis does not currently seem warranted for van der Waals contacts. The van der Waals radius of, for example, an olefinic hydrogen atom is presumably shorter in directions along the bond than the van der Waals radius of a paraffinic hydrogen atom, but probably by a relatively small amount, perhaps 0.02 Å or so.)

It is well known, for example, that the carbon-nitrogen bond in formamide is 0.1 Å shorter than the corresponding bond in methylamine.⁷ Before, however, the shortness of this bond is attributed in part (if not entirely) to an interaction between the "unshared" pair on the nitrogen atom and the electrophilic center at the adjacent carbon atom, it is necessary to consider how the length of a bond is affected by adjacent multiple bonds and by electronegative atoms.

(302) J. B. Goodenough, *J. Phys. Chem. Solids*, **6**, 287 (1958).

(303) E. O. Wollan, *Phys. Rev.*, **117**, 387 (1960).

(304) W. P. Schaefer and R. E. Marsh, *J. Am. Chem. Soc.*, **88**, 178 (1966).

(305) W. P. Schaefer and R. E. Marsh, *Acta Cryst.*, **21**, 735 (1966).

B. EFFECTS OF MULTIPLE BONDS AND
ELECTRONEGATIVE ATOMS ON BOND LENGTHS

The bond about which the most is known regarding its length is the carbon-carbon single bond. Its length varies about 0.16 Å in acyclic compounds, from 1.534 in ethane³⁰⁶ to 1.378 in cyanoacetylene.³⁰⁷ (The carbon-carbon and carbon-nitrogen triple bonds in the latter compound are essentially the same length as those in acetylene and hydrogen cyanide.) Generally, the length of a carbon-carbon single bond is less the greater the adjacent unsaturation. The data have been summarized by Stoicheff³⁰⁸ in the equation

$$r(\text{C}-\text{C}) = 1.299 + 0.040n \quad n = 2, 3, \dots, 6$$

where n is the number of atoms attached to the C-C group; for ethane, $n = 6$; for cyanoacetylene, $n = 2$. For double bonds, Stoicheff gives the equation³⁰⁸

$$r(\text{C}=\text{C}) = 1.226 + 0.028n \quad n = 2, 3, 4$$

Initially, the bond-shortening effect of multiple bonds was attributed to the effects of conjugation³⁰⁹ and hyperconjugation.^{310,311} Later, the effect was expressed, if not explained, by the assumption that the length of a bond tends to decrease as the s character in the overlapping hybrid orbitals that comprise the bond increases.^{103,312-314}

Not only multiple bonds but also electronegative substituents influence the s character of an atomic orbital¹⁰⁹ and (therefore) bond lengths.³¹⁵⁻³¹⁸ The effect of electronegative substituents on bond angles,³¹⁹ spin-spin coupling constants,³²⁰ and inductive constants³²¹ have been summarized in the rule¹⁰³ that atoms tend to concentrate their s character toward electropositive groups. Introduction into a molecule of an electronegative atom should, therefore, make adjacent bonds shorter. The evidence for this has been summarized elsewhere.³²² For bonds to carbon the bond-

shortening effect of an electronegative substituent probably does not exceed 0.02-0.03 Å.

Bond shortening by multiple bonds and electronegative substituents has been attributed to the effects of nuclear-nuclear repulsions.⁶⁵

C. AN ANOMALY

The rule that the s character of an atom tends *not* to be used in orbitals toward electronegative atoms would lead one to suppose that the carbon orbitals of the C-X bonds in $\text{X}_2\text{C}=\text{O}$ contain more s character than do the carbon orbitals of the C-X bonds in $\text{X}_2\text{C}=\text{CH}_2$, O being more electronegative than CH_2 . This supposition is supported by the following data.

1. Inductive constants for phenyl and acetyl groups acting through methylene have been given as +0.215 and +0.60, respectively³²¹ (a positive value indicates that the group is electron withdrawing with respect to hydrogen). Similarly, for 1-propenyl and acetyl acting directly on a functional group, inductive constants of +0.360 and +1.65, respectively, have been given.³²¹ These results are consistent with the previously stated supposition regarding the distribution of s character in molecules, if it is assumed that the electronegativity of an atomic valency is a monotonically increasing function of its s character.^{109,323-325}

2. Aliphatic, ethylenic, and acetylenic protons have direct spin-spin coupling constants to carbon-13 of 126, 155, and 248 cps, respectively.³²⁶ This trend implies that the proton-C¹³ spin-spin coupling constant, J_{CH} , increases with an increase in s character of the carbon orbital of the C-H bond. For the aldehydic proton of acetaldehyde, J_{CH} is 173 cps, significantly larger than the value of 155 for ethylenic protons.^{320,327}

3. Halogen pure quadrupole resonance spectra show many trends that would be expected if it is assumed that an inductive mechanism³²⁸ is the important effect operating. The resonances for Cl³⁵ in CH_3Cl , CH_2Cl_2 , CHCl_3 , and CCl_4 , for example, are 34.0, 36.0, 38.3, and 40.6 Mc, respectively.³²⁹ In the series $\text{Cl}-\text{CH}_2-\text{R}$, $\text{R}=\text{CH}_3$, C_6H_5 , $\text{CH}=\text{CHC}_6\text{H}_5$, and $\text{C}\equiv\text{CH}$, the values are 32.7, 33.6, 33.6, and 35.8, respectively.³²⁹ When R is the acetyl group, the value is 35.3, significantly larger than the value of 33.6 for the ethylenic compound.³²⁹

4. The HCH angle in ethylene^{330,331} is several degrees less than 120°. The corresponding angle in

(306) H. C. Allen, Jr., and E. K. Plyler, *J. Chem. Phys.*, **31**, 1062 (1959).

(307) C. C. Costain, *ibid.*, **29**, 864 (1958).

(308) B. P. Stoicheff, *Tetrahedron*, **17**, 135 (1962).

(309) C. A. Coulson, "Valence," Oxford University Press, London, 1952.

(310) R. S. Mulliken, C. A. Rieke, and W. G. Brown, *J. Am. Chem. Soc.*, **63**, 41 (1941).

(311) J. W. Baker, "Hyperconjugation," Oxford University Press, London, 1952.

(312) M. G. Brown, *Trans. Faraday Soc.*, **55**, 694 (1959).

(313) G. R. Somayajulu, *J. Chem. Phys.*, **31**, 919 (1959).

(314) M. J. S. Dewar and H. N. Schmeising, *Tetrahedron*, **5**, 166 (1959).

(315) L. O. Brockway, *Acta Cryst.*, **7**, 682 (1954).

(316) H. J. Bernstein, *J. Phys. Chem.*, **56**, 351 (1952).

(317) T. L. Cottrell and L. E. Sutton, *Quart. Rev.* (London), **2**, 260 (1948).

(318) H. A. Skinner and L. E. Sutton, *Trans. Faraday Soc.*, **40**, 164 (1944).

(319) C. E. Mellish and J. W. Linnett, *ibid.*, **50**, 657 (1954).

(320) N. Muller and D. E. Pritchard, *J. Chem. Phys.*, **31**, 1471 (1959).

(321) R. W. Taft in "Steric Effects in Organic Chemistry," M. S. Newman, Ed., John Wiley and Sons, Inc., New York, N. Y., 1956, Chapter 13.

(322) H. A. Bent, *J. Chem. Phys.*, **33**, 1260 (1960).

(323) A. D. Walsh, *Discussions Faraday Soc.*, **2**, 18 (1947).

(324) R. S. Mulliken, *J. Phys. Chem.*, **41**, 318 (1937).

(325) W. Moffitt, *Proc. Roy. Soc. (London)*, **A202**, 534 (1950).

(326) N. Muller and D. E. Pritchard, *J. Chem. Phys.*, **31**, 768 (1959).

(327) N. Muller, *ibid.*, **36**, 359 (1962).

(328) H. A. Bent, *Can. J. Chem.*, **38**, 1235 (1960).

(329) H. O. Hopper and P. J. Bray, *J. Chem. Phys.*, **33**, 334 (1960).

(330) L. S. Bartell and R. A. Bonham, *ibid.*, **27**, 1414 (1957).

(331) H. C. Allen, Jr., and E. K. Plyler, *J. Am. Chem. Soc.*, **80**, 2673 (1958).

formaldehyde appears to be somewhat larger.²³¹ Similarly, the FCF angle appears to increase in going from $F_2C=CH_2$ to $F_2C=O$,³³² in keeping with the supposition that the carbon orbitals of the C-F bonds of $F_2C=O$ contain more s character than do those of the C-F bonds of $F_2C=CH_2$. On the other hand, there is a definite decrease in the angle ClCCl in going from $ClC=CH_2$ to $Cl_2C=O$.²⁸¹

In summary, evidence from inductive constants, proton-carbon-13 coupling constants, and halogen quadrupole resonance spectra, if not bond angles, supports the view that the carbon orbitals of the C-X bonds in $X_2C=O$ contain more s character than do those of the C-X bonds in $X_2C=CH_2$; yet the C-X bonds are generally longer in $X_2C=O$ than in $X_2C=CH_2$.³³³ These and other bonds that, from the standpoint of the s-character rule, are abnormally long are identified in the following section. The importance of such anomalies has been stressed by Wheatley.²⁸⁰

A comprehensive summary of interatomic distances published prior to 1956 is given by Sutton;²⁸¹ a supplement³³⁴ covers the period 1956-1959. Useful compilations of interatomic distances have been given for carbon-carbon bonds,^{303,312,314,335,336} carbon-hydrogen bonds,^{312,336-338} carbon-halogen bonds,^{312,339} bonds between first-row elements,^{103,322} and bonds in saturated hydrocarbons,^{340,341} acetylenes,³⁴² acetyl compounds,³⁴³ simple organic compounds,^{307,344} substituted silanes,^{345,346} methyl-substituted phosphines,³⁴⁷ and other covalent compounds.³⁴⁸ The stated uncertainties in the bond lengths cited in the following section is generally less than $\pm 0.01-0.02 \text{ \AA}$.

D. ABNORMALLY LONG BONDS

1. $>C-C \leq$ Bonds

Lengths for bonds of this type that have been well characterized are listed in Table XI.³⁴⁹⁻³⁵⁴ Con-

- (332) V. W. Laurie, *J. Chem. Phys.*, **34**, 291 (1961).
 (333) C. C. Costain and J. R. Morton, *ibid.*, **31**, 389 (1959).
 (334) L. E. Sutton, Ed., "Tables of Interatomic Distances and Configuration in Molecules and Ions," Special Publication No. 18, The Chemical Society, London, 1965.
 (335) M. J. S. Dewar and H. N. Schmeising, *Tetrahedron*, **11**, 96 (1960).
 (336) C. C. Costain and B. P. Stoicheff, *J. Chem. Phys.*, **30**, 777 (1959).
 (337) D. P. Stevenson and J. A. Ibers, *Ann. Rev. Phys. Chem.*, **9**, 359 (1958).
 (338) C. W. N. Cumper, *Trans. Faraday Soc.*, **54**, 1261 (1958).
 (339) H. A. Bent, *J. Chem. Phys.*, **32**, 1532 (1960).
 (340) R. A. Bonham and L. S. Bartell, *J. Am. Chem. Soc.*, **81**, 3491 (1959).
 (341) R. A. Bonham, L. S. Bartell, and D. A. Kohl, *ibid.*, **81**, 4765 (1959).
 (342) B. Bak, D. Christensen, L. Hansen-Nygaard, and E. Tannenbaum, *J. Chem. Phys.*, **26**, 241 (1957).
 (343) L. C. Krisher and E. B. Wilson, Jr., *ibid.*, **31**, 882 (1959).
 (344) B. Bak and L. Hansen-Nygaard, *ibid.*, **33**, 418 (1960).
 (345) J. D. Swalen and B. P. Stoicheff, *ibid.*, **28**, 671 (1958).
 (346) L. C. Krisher and L. Pierce, *ibid.*, **32**, 1619 (1960).
 (347) L. S. Bartell, *ibid.*, **32**, 832 (1960).
 (348) I. Lindqvist, *Nova Acta Regiae Soc. Sci. Upsalensis*, [4] 17, No. 11 (1960).

trary to the implications of the s-character rule, the CH_3-C bond appears to increase in length in going from $CH_3C(=CH_2)Y$ (no. 1-3) to $CH_3-C(=O)Y$ (no. 4-9). An exception to this statement may be isobutylene (no. 3).

TABLE XI
CH₃-C BOND LENGTHS IN CH₃C(=X)Y

| No. | X | Y | Bond length, Å | Ref |
|-----|------------------|------------------|----------------|-----|
| 1 | CH ₂ | H | 1.479 | 344 |
| | | | 1.488 | 349 |
| 2 | CCH ₂ | H | 1.48 | 350 |
| | | | 1.505 | 351 |
| 3 | CH ₂ | CH ₃ | 1.507 | 352 |
| | | | 1.490 | 343 |
| 4 | O | CN | 1.490 | 343 |
| 5 | O | Cl | 1.499 | 343 |
| 6 | O | H | 1.501 | 343 |
| 7 | O | F | 1.503 | 343 |
| 8 | O | CH ₃ | 1.515 | 353 |
| 9 | O | OCH ₃ | 1.52 ± 0.04 | 354 |

2. $>C-C \equiv$ Bonds

Contrary to the implications of the hybridization-electronegativity hypotheses, the data in Table XII³⁵⁵⁻³⁵⁹ show that substitution of fluorine for hydrogen in $CH_3C \equiv Y$ generally causes the carbon-carbon single bond to become longer (compare no. 1-6 with 10-12; 13 and 14 may constitute exceptions to this rule).

TABLE XII
CX₃-C BOND LENGTH IN CX₃C≡Y

| No. | X | Y | Bond length, Å | Ref |
|-----|------------------------|------------------|----------------|-----|
| 1 | H | CH | 1.459 | 336 |
| | | | 1.460 | 342 |
| 2 | H | N | 1.458 | 336 |
| | | | 1.460 | 342 |
| 3 | H | CCN | 1.458 | 335 |
| | | | 1.454 | 336 |
| 4 | H | CCl | 1.458 | 281 |
| 5 | H | Cl | 1.459 | 342 |
| 6 | H | CCF ₃ | 1.455 | 342 |
| 7 | Cl | N | 1.460 | 355 |
| | | | 1.465 | 356 |
| 8 | CH ₃ | N | 1.460 | 357 |
| 9 | Cl, H, H | CH | 1.458 | 358 |
| 10 | F | CH | 1.464 | 281 |
| 11 | F | N | 1.464 | 281 |
| 12 | F | CCF ₃ | 1.465 | 281 |
| 13 | CH ₃ , H, H | N | 1.4735 | 359 |
| 14 | F | CCH ₃ | 1.455 | 342 |

- (349) D. R. Lide, Jr., and D. E. Mann, *J. Chem. Phys.*, **27**, 868 (1957).
 (350) D. R. Lide, Jr., and D. E. Mann, *ibid.*, **27**, 874 (1957).
 (351) L. S. Bartell and R. A. Bonham, *ibid.*, **32**, 824 (1960).
 (352) V. W. Laurie, *ibid.*, **34**, 1516 (1961).
 (353) J. D. Swalen and C. C. Costain, *ibid.*, **31**, 1562 (1959).
 (354) J. M. O'Gorman, W. Shand, Jr., and V. Schomaker, *J. Am. Chem. Soc.*, **72**, 4222 (1950).
 (355) J. G. Baker, D. R. Jenkins, C. N. Kenney, and T. M. Sudgen, *Trans. Faraday Soc.*, **53**, 1397 (1957).
 (356) R. L. Livingston, W. L. Page, and C. N. R. Rao, *J. Am. Chem. Soc.*, **82**, 5048 (1960).
 (357) T. Sparstad and E. Ambule, *J. Chem. Phys.*, **27**, 317 (1957).
 (358) E. Hirota, T. Oka, and Y. Morino, *ibid.*, **29**, 444 (1958).
 (359) R. G. Lerner and B. P. Dailey, *ibid.*, **26**, 678 (1957)

3. $\equiv C-C \leq$ Bonds

Data for these bonds are given in Table XIII.³⁶⁰ They resemble the data in Table XI in that the change from

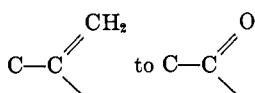

is accompanied by an increase in length of the carbon-carbon single bond (cf. no. 1 and 2 with 3 and 4; no. 5 and 6 imply that the present rule may be applied to cases where the trigonally hybridized carbon atom is part of an aromatic system).

TABLE XIII

| XC-CYZ BOND LENGTH IN X \equiv CC(=Y)Z | | | | | |
|--|--------------------|---|-----------------|----------------|----------|
| No. | X | Y | Z | Bond length, Å | Ref |
| 1 | CH ₃ CC | CH ₂ | H | 1.42 | 312, 360 |
| 2 | N | CH ₂ | H | 1.426 | 336 |
| 3 | HC | O | H | 1.4446 | 333 |
| 4 | N | O | CH ₃ | 1.466 | 343 |
| 5 | | NCC ₆ H ₅ | | 1.419 | 312 |
| 6 | | C ₆ H ₅ -CC-C ₆ H ₅ | | 1.40 | 312 |

4. $\geq C-C \leq$ Bonds

In Table XIV,³⁶¹⁻³⁶⁷ eight single bonds between tri-

TABLE XIV

LENGTH OF THE CARBON-CARBON SINGLE BOND IN STRUCTURES OF THE TYPE $\geq C-C \leq$

| No. | Molecule | Length of the C-C single bond, Å | Ref |
|-----|-------------------|----------------------------------|----------|
| 1 | Cyclooctatetraene | 1.462 | 361 |
| 2 | | 1.483 | 336, 362 |
| 3 | | 1.48 | 363 |
| 4 | | 1.50 | 364 |
| 5 | | 1.50 | 360 |
| 6 | | 1.53 ± 0.08 | 365 |
| 7 | | 1.54 | 366 |
| 8 | | 1.54 planar 1.56 twisted | 367 |

gonally hybridized carbon atoms have been listed in order of increasing bond length. Broadly speaking,

(360) P. W. Allen and L. E. Sutton, *Acta Cryst.*, **3**, 46 (1950).

(361) O. Bastiansen, L. Hedberg, and K. Hedberg, *J. Chem. Phys.*, **27**, 1311 (1957).

(362) A. Almennigen, O. Bastiansen, and M. Traetteberg, *Acta Chem. Scand.*, **12**, 1221 (1958).

(363) O. Bastiansen, *ibid.*, **3**, 408 (1949).

(364) L. L. Merritt, Jr., and E. D. Schroeder, *Acta Cryst.*, **9**, 801 (1956).

(365) M. W. Dougill and G. A. Jeffrey, *ibid.*, **6**, 831 (1953).

(366) E. M. Ayerst and J. R. C. Duke, *ibid.*, **7**, 588 (1954).

(367) G. A. Jeffrey and G. S. Parry, *J. Am. Chem. Soc.*, **76**, 5283 (1954).

there appears to exist a correlation between the length of the central carbon-carbon bond and the electronegativities of the attached substituents; however, this correlation is in a direction opposite to that which has been taken as "normal." The more electronegative the substituents, the longer the bond.

5. $> C-C <$ Bonds

While the C-C distance in perfluoroethane is significantly shorter than the C-C distance in ethane (1.51 Å²⁸¹ compared to 1.534 Å for ethane^{306,368}), the C-C bond is very little, if any, shorter in ethyl fluoride (1.533 Å³⁶⁹) and may even be longer than in ethane in ethyl chloride and ethyl bromide (for both of the latter compounds the C-C distance is reported to be 1.5495 ± 0.005 Å^{370,371}).

6. $> C-O-$ Bonds

Replacement of the hydroxyl hydrogen in methyl alcohol by the formyl group, -CHO, results in an expansion of the C(methyl)-oxygen bond from 1.427 ± 0.007 Å, its value in methyl alcohol,²⁸¹ to 1.437 ± 0.01 Å, its value in methyl formate.³⁷² From the viewpoint of the previous discussion, this change is doubly anomalous, first, because any resonance of structure 17a with 17b,^{7,373} in which the ester oxygen is (by the σ - π approximation) approximately trigonally hybridized (the bond angle in ozone is 116.8°), should increase the s character at the oxygen end of the CH₃-O

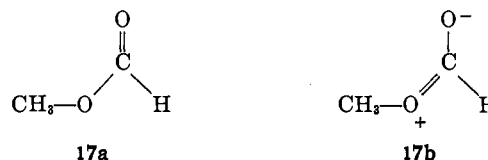

bond and lead to a shortened bond; and, second, because the change from the substituent H to CHO on oxygen is a change from a substituent of lesser electronegativity to one of greater electronegativity,³²¹ and this, too, ought to lead to a shortened C(methyl)-oxygen bond.

An anomalously large value of 1.46 ± 0.05 Å has also been reported for the C(methyl)-oxygen distance in crystalline dimethyl oxalate.³⁶⁵

7. C-N Bonds

Extension of the hybridization hypothesis from carbon to nitrogen would lead one to expect the C-N dis-

(368) K. Hedberg and V. Schomaker, *ibid.*, **73**, 1482 (1951).

(369) B. Bak, S. Detoni, L. Hansen-Nygaard, and J. T. Nielsen, *Spectrochim. Acta*, **16**, 376 (1960).

(370) R. S. Wagner and B. P. Dailey, *J. Chem. Phys.*, **26**, 1588 (1957).

(371) R. S. Wagner, B. P. Dailey, and N. Solimene, *ibid.*, **26**, 1593 (1957).

(372) R. F. Curl, Jr., *ibid.*, **30**, 1529 (1959).

(373) G. W. Wheland, "Resonance in Organic Chemistry," John Wiley and Sons, Inc., New York, N. Y., 1955.

tance in nitromethane, in which the nitrogen atom is trigonally hybridized, to be shorter, perhaps by 0.04 Å or so, than the C-N distance in methylamine, in which the nitrogen atom is tetrahedrally hybridized. Actually, the two bond lengths are practically the same.²⁸¹ Additional examples of long bonds to the nitro group are listed in part 14 below (see also part 13). From the point of view of electronegativity effects, the C-N distance in urea (1.35 Å) is anomalous relative to that in thiourea (1.33 Å³⁷⁴).

8. $\geq C-Cl$ Bonds

Fluorination often causes chemical bonds to become shorter.^{315,322} This is consistent with the hybridization hypothesis. The C-Cl bond in CCl_2F_2 appears to be anomalously long, however, relative to the length of this bond in CH_2Cl_2 and CCl_4 .²⁸¹

| | | | |
|--------------|---------|--------------|---------|
| Cl- $CClF_2$ | 1.775 Å | Cl- CH_2Cl | 1.772 Å |
| | | Cl- CCl_3 | 1.766 Å |

9. $\geq C-hal$ Bonds

Substitution of chlorine for hydrogen in C_2H_3Cl may cause an increase in C-Cl bond length.³¹² More striking, and more certain, is the anomalous trend exhibited in Table XV,³⁷⁵ where it is seen that long bonds between chlorine and carbon occur when the carbon atom is doubly bonded to oxygen (cf. parts 1, 3, and 4). Particularly anomalous is the length of the C-Br bond in carbonyl bromide.²⁸¹ It is probably significant that, as shown in Table XVI,³⁷⁶⁻³⁷⁹ this trend does not occur for $\geq C-F$ bonds. The order of the C-F bonds in Table

TABLE XV

| Cl-C BOND LENGTH IN Cl-C(=X)Y | | | | |
|-------------------------------|---------|---------|---------------------|-----|
| No. | X | Y | Cl-C bond length, Å | Ref |
| 1 | S | Cl | 1.70 | 281 |
| 2 | CCl_2 | Cl | 1.72 | 281 |
| 3 | O | Cl | 1.746 | 281 |
| 4 | O | OCH_3 | 1.75 | 354 |
| 5 | O | CH_3 | 1.789 | 375 |

TABLE XVI

| F-C BOND LENGTH IN F-C(=X)Y | | | | |
|-----------------------------|--------|--------|--------------------|-----|
| No. | X | Y | F-C bond length, Å | Ref |
| 1 | CF_2 | F | 1.30 | 281 |
| | | | 1.313 | 281 |
| 2 | O | F | 1.32 | 281 |
| 3 | CH_2 | F | 1.321 | 281 |
| 4 | O | H | 1.341 | 376 |
| | | | 1.343 | 377 |
| | | | 1.351 | 281 |
| 5 | CH_2 | H | 1.344 | 378 |
| 6 | O | CH_3 | 1.348 | 379 |

(374) N. R. Kunchur and M. R. Truter, *J. Chem. Soc.*, 2551 (1958).

(375) K. M. Sinnott, *J. Chem. Phys.*, **34**, 851 (1961).

(376) O. H. LeBlanc, Jr., V. W. Laurie, and W. D. Gwinn, *ibid.*, **33**, 598 (1960).

(377) R. F. Stratton and A. H. Nielsen, *J. Mol. Spectry.*, **4**, 373 (1960).

(378) H. W. Morgan and J. H. Goldstein, *J. Chem. Phys.*, **30**, 1025 (1959).

(379) L. Pierce and L. C. Krisher, *ibid.*, **31**, 875 (1959).

XVI is almost the order given by the hybridization-electronegativity hypothesis.^{103,322,328,339}

10. $\geq C-P, As$ Bonds

Substitution of fluorine for hydrogen in $(CH_3)_3P$ and $(CH_3)_3As$ causes the C-P and C-As bonds to increase in length from 1.87 to 1.94 and 1.98 to 2.05 Å, respectively.³⁴⁸

11. $\geq C-H$ Bonds

Data for these bonds are given in Table XVII.³⁸⁰⁻³⁸³ The anomalous increase in C-H bond length in going from the structure

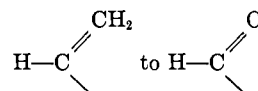

is similar to changes in bond length described above in parts 1, 3, 4, and 9. If there is any correlation between the C-H distance and the electronegativity of Y (Table XVII), it is once again (part 4) often in the reverse direction from that expected (note especially no. 1-6).

TABLE XVII

H-C BOND LENGTHS IN H-C(=X)Y

| No. | X | Y | Length of H-C bond in H-CXY | Ref |
|-----|--------|----------|-----------------------------|-----|
| 1 | CH_2 | CH_3 | 1.070 | 349 |
| 2 | CHF | H | 1.075 | 378 |
| 3 | CH_2 | F | 1.080 | 378 |
| 4 | CH_2 | H | 1.085 | 330 |
| | | | 1.086 | 331 |
| 5 | CH_2 | CN | 1.0863 | 336 |
| 6 | H | C_6H_5 | 1.084 | 380 |
| 7 | O | F | 1.100 | 376 |
| 8 | O | OCH_3 | 1.101 | 372 |
| 9 | O | NH_2 | 1.102 | 381 |
| 10 | O | CCH | 1.1064 | 333 |
| 11 | O | CH_3 | 1.114 | 382 |
| 12 | O | H | 1.12 | 383 |

12. H-Heavy Atom Bonds

The difficulties in determining accurately unambiguous hydrogen-heavy atom distances have frequently been stressed.^{320,326,330,337,340,384-388} Nonetheless, it is probably correct to say that the C-H distance decreases along the series CHF_3 , $CHCl_3$, $CHBr_3$,³⁸⁷ and that it varies in an irregular fashion in the series CH_4 , CH_3F ,

(380) A. Langseth and B. P. Stoicheff, *Can. J. Phys.*, **34**, 350 (1956).

(381) C. C. Costain and J. M. Dowling, *J. Chem. Phys.*, **32**, 158 (1960).

(382) R. W. Kilb, C. C. Lin, and E. B. Wilson, Jr., *ibid.*, **26**, 1695 (1957).

(383) G. Erlandsson, *ibid.*, **25**, 579 (1956).

(384) S. L. Miller, L. C. Aamodt, G. Dousmanis, and C. H. Townes, *ibid.*, **20**, 1112 (1952).

(385) J. H. Calloman and B. P. Stoicheff, *Can. J. Phys.*, **35**, 373 (1957).

(386) V. W. Laurie, *J. Chem. Phys.*, **28**, 704 (1958).

(387) C. H. Townes and A. L. Schawlow, "Microwave Spectroscopy," McGraw-Hill Book Co., Inc., New York, N. Y., 1955.

(388) D. P. Stevenson and J. A. Ibers, *J. Chem. Phys.*, **33**, 762 (1960).

CH_2F_2 , CHF_3 . In a tabulation of C-H distances for CH_3X compounds,³³⁷ the C-H distance decreases along the series $\text{X} = \text{F}, \text{Cl}, \text{Br}, \text{I}, \text{C}\equiv\text{CH}, \text{N}\equiv\text{C}, \text{H}, \text{C}\equiv\text{N}, \text{CHO}$. All of these trends are anomalous from the standpoint of the hybridization-electronegativity hypothesis. Additional anomalies are illustrated in Table XVIII.³⁸⁹

TABLE XVIII
HYDROGEN-HEAVY ATOM BOND LENGTHS IN MOLECULES
ISOELECTRONIC WITH METHANE AND ETHANE

| No. | Molecule | Bond | Bond length, Å | Ref |
|-----|--|-----------------------------------|----------------|-----|
| 1 | CH_4 C_2H_6 | H-CH ₃ | 1.094 | 281 |
| | | H-CH ₂ CH ₃ | 1.107 | 389 |
| | | | 1.114 | 368 |
| 2 | NH_3 | H-NH ₂ | 1.008 | 281 |
| | | | 1.016 | 281 |
| 3 | N_2H_4 H_2O H_2O_2 | H-NHNH ₂ | 1.04 | 281 |
| | | H-OH | 0.9584 | 281 |
| | | H-OOH | 0.97 | 281 |

It is well known that the C-H distance in methane is probably³⁸⁸ less than that in ethane. The data cited in Table XVIII suggest that an analogous change may occur in the hydrogen-heavy atom distance in going from ammonia to hydrazine and water to hydrogen peroxide (in these comparisons, the first member is isoelectronic with methane, the second with ethane). In the methane-ethane comparison, it may be correct to ascribe part of the change to an electronegativity effect (the s character in the C-H bonds should decrease when hydrogen is replaced by the less electronegative methyl group). Consistent with this is the fact that the C-C distance in ethane and higher alkanes is slightly less than the interatomic distance in diamond.³⁹⁰ Both the NH₂ group and the OH group are more electronegative than hydrogen, however, and therefore the hybridization-electronegativity hypothesis cannot account for the second and third comparisons in Table XVIII.

13. hal-NO Bonds

The hal-NO bond lengths in FNO, ClNO, and BrNO are 1.52, 1.95, and 2.14 Å, respectively.²⁸¹ It has long been known that these distances are abnormally long.³⁹¹ They exceed the sum of the normal covalent radius of the halogen atom and the nitrogen atom (one-half the N-N distance in hydrazine) by 0.07, 0.22, and 0.27 Å, respectively. For comparison, the N-hal distances in NF₃ and NCl₂H are 1.37 and 1.76 Å, respectively.²⁸¹ It has been pointed out³⁹² that attributing the long

hal-NO bond length to increased ionic character contradicts the Schomaker-Stevenson rule.³⁹³ Other bond lengths that are anomalous from the point of view of this rule have been noted.³⁹⁴ Certain of these anomalous departures from bond-length additivity have been tentatively ascribed to hybridization effects.³⁹⁵ The present instances are closely analogous to the long bonds cited in part 9.

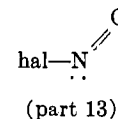
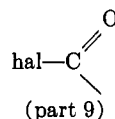

14. R-NO₂ Bonds

It is a general rule that bonds to the nitro group are abnormally long. The case of nitromethane has already been cited. Probably the best known example is the N-N bond in dinitrogen tetroxide³⁹⁶ itself. The comparisons below show that dinitrogen trioxide,³⁹⁷ chloropicrin,³⁹⁸ and nitryl chloride³⁹⁹ contain abnormally long bonds, also. The increase in C-N bond length (Å) in going from CH_3NO_2 to CCl_3NO_2 is noteworthy, too.

| | | | |
|----------------------------------|-------|-----------------------------------|------|
| ON-NO ₂ | 1.85 | | |
| O ₂ N-NO ₂ | 1.750 | | |
| H ₂ N-NH ₂ | 1.47 | CCl ₃ -NO ₂ | 1.59 |
| Cl-NO ₂ | 1.84 | CH ₃ -NO ₂ | 1.47 |
| Cl-NCIH | 1.76 | CH ₃ -NH ₂ | 1.47 |

Dinitrogen tetroxide is isoelectronic with structures 7 and 8 in Table XIV. Wheatley has pointed out that in all such structures a shortened central bond would, on the resonance hypothesis, be expected, but that in fact in no case does the experimental evidence show such a shortening.²⁸⁰ A lengthened bond is particularly noticeable in structures of the type XYA-AXY when both X and Y carry unshared pairs⁴⁰⁰ (Table XIV). B₂Cl₄, in which the B-B bond is said to be 0.20 Å longer than normal,⁴⁰¹ is possibly another example.

15. CH₃-(Donor Atom) Bonds

Lindqvist has pointed out that when a donor atom shares a pair of electrons with an electron-deficient group, the original bonds to the donor atom often become longer,³⁴⁸ as shown in Table XIX. This behavior is in marked disagreement with the implications of the hybridization hypothesis.

(389) A. Almennigen and O. Bastiansen, *Acta Chem. Scand.*, **9**, 815 (1955).

(390) L. S. Bartell, *J. Am. Chem. Soc.*, **81**, 3497 (1959).

(391) J. A. A. Ketelaar and K. J. Palmer, *ibid.*, **59**, 2629 (1937).

(392) P. W. Allen and L. E. Sutton, *Trans. Faraday Soc.*, **47**, 236 (1951).

(393) V. Schomaker and D. P. Stevenson, *J. Am. Chem. Soc.*, **63**, 37 (1941).

(394) A. F. Wells, *J. Chem. Soc.*, 55 (1949).

(395) H. A. Bent, *J. Chem. Phys.*, **33**, 304 (1960).

(396) D. W. Smith and K. Hedberg, *ibid.*, **25**, 1282 (1956).

(397) R. L. Kuczkowski, *J. Am. Chem. Soc.*, **87**, 5259 (1965).

(398) W. M. Barss, *J. Chem. Phys.*, **27**, 1260 (1957).

(399) D. J. Miller and K. M. Sinnott, *J. Chem. Soc.*, 350 (1958).

(400) P. J. Wheatley, *ibid.*, 4514 (1956).

(401) M. Atoji, W. N. Lipscomb, and P. J. Wheatley, *J. Chem. Phys.*, **23**, 1176 (1955).

TABLE XIX
EFFECT ON BOND LENGTH OF SHARING LONE-PAIR ELECTRONS

| No. | Molecule | Bond | Bond length, ^{281,448} Å |
|-----|---|------|-----------------------------------|
| 1 | (CH ₃) ₂ N | C-N | 1.47 |
| | (CH ₃) ₂ NBF ₃ | C-N | 1.50 |
| | (CH ₃) ₂ HN | C-N | 1.47 |
| | (CH ₃) ₂ HNBF ₃ | C-N | 1.50 |
| 2 | (CH ₃) ₂ N | C-N | 1.47 |
| | (CH ₃) ₂ NO | C-N | 1.54 |
| 3 | (CH ₃) ₂ O | C-O | 1.43 |
| | (CH ₃) ₂ OBF ₃ | C-O | 1.45 |
| 4 | (CH ₃) ₂ SO | C-S | 1.82 |
| | (CH ₃) ₂ SO ₂ | C-S | 1.90 |

16. >C=O Bonds

Eleven well-characterized carbon-oxygen double bonds are listed in order of decreasing length in Table XX.⁴⁰² Broadly speaking, there is observed the expected correlation between C=O bond length in XYC=O and the sum of the electronegativities of the substituents X and Y, the former tending to decrease as the latter increases.¹⁰³ Compounds that appear to be noticeably out of order are 10 and 11. From the standpoint of the resonance hypothesis,⁷ the relatively short C=O bonds in compounds 5 and 6 are puzzling. Compound 5 was commented upon in part 6.

TABLE XX
LENGTH OF THE CARBON-OXYGEN DOUBLE BOND IN XYC=O

| No. | X | Y | Length of the C=O in XYC=O, Å | Ref |
|-----|-----------------|------------------|-------------------------------|-----|
| 1 | H | CH ₃ | 1.226 | 402 |
| | | | 1.2155 | 382 |
| 2 | H | CN | 1.226 | 343 |
| | | | 1.225 | 281 |
| 3 | H | H | 1.21 | 383 |
| | | | 1.215 | 333 |
| 4 | H | CCH | 1.200 | 372 |
| | | | 1.193 | 381 |
| 5 | H | OCH ₃ | 1.192 | 343 |
| | | | 1.183 | 376 |
| 6 | H | NH ₂ | 1.181 | 379 |
| | | | 1.17 | 281 |
| 7 | CH ₃ | Cl | 1.183 | 376 |
| | | | 1.181 | 379 |
| 8 | CH ₃ | F | 1.181 | 379 |
| | | | 1.17 | 281 |
| 9 | F | F | 1.17 | 281 |
| | | | 1.166 | 281 |
| 10 | Cl | Cl | 1.17 | 281 |
| | | | 1.166 | 281 |
| 11 | Cl | Cl | 1.17 | 281 |
| | | | 1.166 | 281 |

17. Summary

The principal features of the data reviewed in parts 1-16 may be summarized in the following statements.

(a) Bonds to carbonyl carbon atoms are abnormally long. Data supporting this statement have been given for bonds between carbonyl carbon atoms and the substituents CH₃, Cl, Br, H, C≡X, and C(=X)Y. It is a generalization of the conclusion that "...substitution of an O atom [for =CH₂] lengthens the adjacent single bonds [to C≡CH and H] by 0.02 Å"³⁸³ (regarding the figure 0.02 Å, see, however, below, item f).

(b) Bonds between halogen atoms and the nitroso group (-NO, which is isoelectronic with -CHO) are

abnormally long, particularly in the case of chlorine and bromine.

(c) Bonds to fluorinated carbon atoms are sometimes abnormally long. Examples have been given for bonds to fluorinated carbon atoms from phosphorus, arsenic, chlorine (but not fluorine), hydrogen, oxygen, and carbon.

(d) The central bond in the structure XYA-AYX is abnormally long when the atoms X, or X and Y, are nitrogen or oxygen atoms.

(e) Bonds to the nitro group are abnormally long.

(f) Bonds between oxygenated atoms and the heavier halogens, Cl and Br, are particularly long. The difference between the observed bond length and the corresponding covalent radius sum increases in the order F < Cl < Br (the corresponding iodine compounds are often unstable or nonexistent).

(g) No long bonds of the type ≡C-C≡ have been reported.

Generally speaking, attached to one or both atoms of a long bond is a nitrogen, oxygen, or fluorine atom.

The existence of abnormally long bonds of the type cataloged above supports the view^{327,344,403,404} that an electronegativity-hybridization model,¹⁰³ by itself, cannot account for the variability of bond lengths in covalent compounds. It is well known that the reactivities of such compounds cannot be adequately described solely in terms of an inductive (or inductive-hybridization³²⁸) mechanism.⁴⁰⁵⁻⁴⁰⁷

18. Interpretation: Bond Lengthening by Lone Pairs

Is it possible to interpret electronically the existence of abnormally long bonds?

Lindqvist has observed that a change in the substituents attached to atoms A or B of a bond A-B frequently results in a lengthened A-B bond if the change is such as to increase the polarity of this bond.³⁴⁸ Supporting cases cited by Lindqvist have been listed above in parts 5, 10, and 15. The change from (CH₃)₂N to (CH₃)₂NO, for example, presumably increases the polarity, and does in fact increase the length, of the carbon-nitrogen bond (Table XIX, no. 2). Additional cases in support of Lindqvist's suggestion may be found in parts 1, 6, 11, and 12, when allowance is made for the effect of orbital hybridization on atom electronegativity.¹⁰³ A carbon sp² valency, for example, is more electronegative than a carbon sp³ valency; therefore, the change from

(403) R. S. Mulliken, *Tetrahedron*, **6**, 68 (1959).

(404) D. R. Lide, Jr., *ibid.*, **17**, 125 (1962).

(405) C. K. Ingold and E. H. Ingold, *J. Chem. Soc.*, 1310 (1926).

(406) C. K. Ingold, *Chem. Rev.*, **15**, 225 (1934).

(407) C. K. Ingold, "Structure and Mechanism," Cornell University Press, Ithaca, N. Y., 1953.

(402) C. C. Lin and R. W. Kilb, *J. Chem. Phys.*, **24**, 631 (1956).

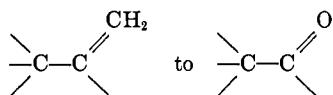

presumably increases the polarity, and does in fact increase the length, of the carbon-carbon single bond (Table XI). On the other hand, the change from

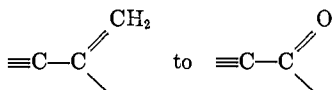

presumably decreases the polarity, but in fact increases the length, of the carbon-carbon single bond (part 3). Also, in the change from $\text{CH}_3\text{-NO}_2$ to $\text{CCl}_3\text{-NO}_2$, the presumed decrease in polarity of the carbon-nitrogen bond is accompanied by an increase in bond length (parts 7 and 14). Equally remarkable is the wide range of lengths exhibited by the central bond in the symmetrical structures XYC-CXY (part 4), where the polarity of this bond vanishes identically. Additional examples that appear to run counter to the implications of the polarity hypothesis may be found in parts 2, 8, 9, and 16.

A statement that describes the electronic environment of most abnormally long bonds is the following: *Attached to atom A or B of an abnormally long bond A-B is at least one atom with an unshared pair.*⁴⁰⁸

This statement does not imply that every structure of the type A-B-C contains an abnormally long bond A-B. It is a generalization of Wheatley's observation⁴⁰⁰ concerning the effect of unshared pairs on the length of the central bond in structures of the type XYA-AYX . Three cases not covered by the statement above are the comparison of H-CH_3 with $\text{H-CH}_2\text{-CH}_3$ (Table XVIII, no. 1), the comparison of C-N and C-O before and after the addition of BF_3 to the donor atom (Table XIX, no. 1 and 3), and the comparison of $\text{CH}_3\text{-OH}$ with $\text{CH}_3\text{-OCHO}$ (part 6). In each of these cases, the change alluded to introduces at a position α

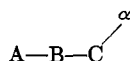

on the substituent C adjacent to the bond A-B that is lengthened a pair of shared electrons where hitherto there were no electrons at all, shared or unshared. In the majority of cases, which are covered by the original statement, the corresponding change is the introduction at α of an unshared pair for a shared pair (or sometimes an unshared pair where previously no pair had existed; see, e.g., Table XIX, no. 2).

Briefly stated, the chemical environment of an abnormally long bond A-B is A-B-C or (less frequently) A-B-C . In this notation, it is understood that the bond between B and C may be, and frequently is, a double bond, and, also, that there may be substituents

in addition to B on A, more than one substituent like C on B (and similarly for A), and more than one lone pair on a substituent (see especially Table XIV).

The bond-lengthening effect of lone pairs may be represented by the diagrams

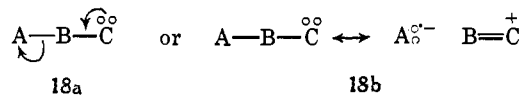

These diagrams imply that the extension of a bond A-B beyond its "normal" value should depend upon (i) the ability of atom C to share its lone pair(s) with atom B, (ii) the ability of atom A to leave with the bonding pair A-B, and (iii) the ability, or inability, of atom B to accommodate additional electrons in its valence shell, or in the near vicinity of its valence shell.

The complex interplay of factors i-iii superimposed on the inductive effects of electronegative groups and multiple bonds, although probably not a complete account of the factors that influence bond lengths, is probably sufficient to account for the difficulties that have been experienced⁴⁰⁹ in discerning systematic trends in bond lengths.

A lone pair on atom C (18a) would be expected to be a relatively good "entering group" if, in the absence of an interaction of the type indicated by the curly arrow in 18a, it would be a relatively basic lone pair; that is to say, if it is relatively localized, in other words, if it is in the valence shell of a small-core atom such as nitrogen, oxygen, or fluorine.

To exert a bond-lengthening effect on a bond A-B, atom C must be attached in such a way that its lone pair has access to the appropriate electrophilic center on atom B. In cyanogen ($:\text{N}\equiv\text{C}-\text{C}\equiv\text{N}:$), for example, the lone pairs on the nitrogen atoms, unlike those in oxamide (Table XIV, no. 7), are unable to interact with the adjacent carbon atoms and the carbon-carbon bond in cyanogen is a normal, short bond (length 1.380 Å).

Additionally, to exert a bond-lengthening effect, atom C should be attached to an atom that, like carbon, nitrogen, or oxygen, cannot easily expand its octet.

For given atoms B and C in a structure A-B-C , the better atom A is at accommodating an unshared pair, the greater should be the extension of the bond A-B beyond its "normal" value. Generally, atom A would be expected to be a good "leaving group" if the anion A^- is a weak base. As remarked in the Summary (part f), particularly long bonds are found between oxygenated atoms of carbon and nitrogen and the atoms Cl and Br, whose anions, Cl^- and Br^- , are very weak bases.

Compounds that contain in the proper conjunction, A-B-C , very good donor atoms C, and very good leav-

(408) H. A. Bent, *J. Chem. Phys.*, **36**, 1090 (1962).

(409) O. Bastiansen and M. Traetteberg, *Tetrahedron*, **17**, 147 (1962).

ing groups A, as, for example, (hypothetical) α -chloramines or carbonyl iodide, respectively, should have particularly long (and reactive) bonds A-B and should be relatively unstable (at room temperature) or, possibly, nonexistent.

19. Associated Short Bonds

Diagrams 18a and 18b imply that with an abnormally long bond A-B ought to be an abnormally short B-C. Particularly short is the carbon-oxygen bond in Cl_2CO (Table XX, no. 11); in Cl_2CO the carbon atom is involved in two abnormally long Cl-Cl bonds (Table XV, no. 3). Also short are the nitrogen-oxygen bonds in ClNO and BrNO .

Generally, the bond-shortening effect of lone pairs on the bond B-C in a structure A-B-C is larger the weaker the base A⁻ (Table XX), particularly when atom B cannot easily expand its octet. Put another way, in a structure A-B-C the effect on the length of the bond B-C of changing the substituent A will depend upon the nature of atoms B and C.⁴⁰⁸ The anticipated bond-shortening effect of changing from the substituent hydrogen to a more electronegative substituent, such as chlorine or fluorine, for example (Table XXI, no. 1a, 2a, 3a), may be augmented if there are lone pairs on atom C (Table XXI, no. 1b, 2b, 3b).

TABLE XXI
VARIABLE BOND-SHORTENING EFFECT OF
ELECTRONEGATIVE ATOMS

| No. | Bond | Change in substituent R | Decrease in bond length, Å |
|-----|---------------------------------------|-------------------------|----------------------------|
| 1a | $\text{R}_2\text{C}=\text{CH}_2$ | H to Cl | 0.013 |
| 1b | $\text{R}_2\text{C}=\ddot{\text{O}}$ | H to Cl | 0.059 |
| 2a | $\text{R}_2\text{C}=\text{CH}_2$ | H to F | 0.027 |
| 2b | $\text{R}_2\text{C}=\ddot{\text{O}}$ | H to F | 0.05 |
| 3a | $\text{RH}_2\text{C}-\text{CH}_3$ | H to F | 0.003 |
| 3b | $\text{RH}_2\text{C}-\ddot{\text{F}}$ | H to F | 0.03 |

More complex interactions can be imagined. In the change from $\text{Cl}-\text{CH}_3$ to $\text{Cl}-\text{CH}_2\text{Cl}$, the length of the Cl-C bond decreases, by approximately 0.015 Å. In the change from $\text{Cl}-\text{C}(\text{CH}_3)\text{O}$ to $\text{Cl}-\text{C}(\text{Cl})\text{O}$, the decrease in the length of the Cl-C bond is much larger, approximately 0.043 Å, owing, presumably, to the fact that in Cl_2CO the effect of the unshared electrons on the oxygen atom in lengthening adjacent bonds is expended upon two Cl-C bonds instead of one.

Structurally, there is a close analogy between the intramolecular interactions discussed in this section and the intermolecular interactions discussed in part II of the review. In both instances the interaction between unshared electrons on a donor atom, D (Figure 38), C (18a), with an acceptor atom, A (Figure 38), B (18a), produces an abnormally short interatomic distance between the donor and acceptor atoms. Often, although not always, this interaction produces an ab-

normally long interatomic distance between the acceptor atom and one or more of its substituents, S (Figure 38), A (18a). This bond-lengthening effect of unshared electrons on a donor atom is a function of the ease with which the acceptor atom can expand its octet and the ability of the acceptor atom's substituents to function as leaving groups.

20. Related Physical and Chemical Properties

a. Nuclear quadrupole resonance frequencies

The deviation of a nucleus such as Cl^{35} from spherical symmetry means that, in compounds in which the electric field at the Cl^{35} nucleus is not spherically symmetric, the compound's energy will depend, somewhat, upon the orientation of the Cl^{35} nucleus with respect to the molecular or crystalline electric field.⁴¹⁰ The frequency of the electromagnetic radiation required to flip the Cl^{35} nucleus from one orientation to another increases with a corresponding increase in the asymmetry of the electric field at the Cl^{35} nucleus. Generally, the more ionic a bond R-Cl, in the sense R^+Cl^- , the lower the frequency of the resonance radiation.^{329,411-413} As the electronegativity of R increases, so, generally, does the Cl^{35} resonance frequency (Table XXII). Thus, substitution of H for CH_3 on a carbon atom to which a Cl^{35} nucleus is attached (no. 1-4), or Cl for H (no. 4-7), increases the resonance frequency. Similarly, the change from $\text{C}(\text{sp}^3)$ to $\text{C}(\text{sp}^2)$ to $\text{C}(\text{sp})$ at the same site (no. 3, 8, 9) increases the resonance frequency. The resonance frequency increases also when a relatively remote hydrogen atom or CH_2 group is replaced by an oxygen atom (no. 3 and 10, 8 and 11, respectively). On the other hand, substitution of fluorine atoms for α -chlorine atoms (no. 7, 12, 13) decreases the Cl^{35} resonance frequency.⁴¹¹ Anomalously low Cl^{35} frequencies are found, also, in α -chloro ethers⁴¹³ (no. 14, 15), acyl chlorides (no. 18), and Cl_2CO (no. 17). Unlike the first 11 compounds in Table XXII, there is the possibility in the freons, α -chloro ethers, and acyl chlorides, of an intramolecular donor-acceptor interaction of the type

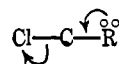

where $\text{R} = \text{O}$ or F .⁴¹³ Consistent with this suggestion is the fact that the change from the molecule $\text{ClCH}_2\text{-CH}_2\text{CH}_3$ to $\text{ClCH}_2\text{CH}_2\text{CH}_2\text{Cl}$ increases only very slightly the Cl^{35} resonance frequency, by approximately 0.07 Mc, whereas the change from the isoelectronic molecule $\text{ClCH}_2\text{OCH}_3$ to $\text{ClCH}_2\text{OCH}_2\text{Cl}$ increases the Cl^{35} frequency by 2.47 Mc, owing, presumably, to the

(410) B. P. Dailey, *J. Phys. Chem.*, **57**, 490 (1953).

(411) R. Livingston, *ibid.*, **57**, 496 (1953).

(412) P. J. Bray and D. Estara, *J. Chem. Phys.*, **22**, 570 (1954).

(413) E. A. C. Lucken, *J. Chem. Soc.*, 2954 (1959).

fact that, in $\text{Cl}-\text{CH}_2\text{OCH}_2-\text{Cl}$, the frequency-lowering effect of the unshared electrons on the oxygen atom is expended on two chlorine atoms instead of one.

TABLE XXII

PURE QUADRUPOLE SPECTRA OF SOLID CHLORINE COMPOUNDS

| No. | Compound | Cl^{35} resonance frequency in Mc at 77°K | Ref |
|-----|--|--|----------|
| 1 | $(\text{CH}_3)_3\text{CCl}$ | 31.067 | 329 |
| 2 | $(\text{CH}_3)_2\text{HCCl}$ | 31.939 | 411 |
| 3 | $(\text{CH}_3)_2\text{H}_2\text{CCl}$ | 32.649, 32.759 | 329 |
| 4 | H_3CCl | 34.029 | 411 |
| 4 | H_3CCl | 34.029 | 411 |
| 5 | ClH_2CCl | 35.991 | 411 |
| 6 | Cl_2HCCl | 38.308, 38.254 | 411 |
| 7 | Cl_3CCl | 40.465-40.817 | 411 |
| 3 | $(\text{H}_3\text{C})\text{CH}_2\text{Cl}$ | 32.649, 32.759 | 329 |
| 8 | $(\text{H}_2\text{C}=\text{CH})\text{CH}_2\text{Cl}$ | 33.455 | 329 |
| 9 | $(\text{HC}\equiv\text{C})\text{CH}_2\text{Cl}$ | 35.812 | 329 |
| 10 | $(\text{C}_6\text{H}_5\text{OCH}_2)\text{CH}_2\text{Cl}$ | 34.316 | 329 |
| 11 | $(\text{O}=\text{CCH}_3)\text{CH}_2\text{Cl}$ | 35.071-35.485 | 329 |
| 7 | Cl_3CCl | 40.465-40.817 | 411 |
| 12° | F_2ClCCl | 38.450 | 411 |
| 13° | F_3CCl | 38.089 | 411 |
| 5 | ClCH_2Cl | 35.991 | 411 |
| 14° | $\text{CH}_3\text{OCH}_2\text{Cl}$ | 29.817, 30.206 | 329, 413 |
| 15° | $\text{ClCH}_2\text{OCH}_2\text{Cl}$ | 32.484 | 411 |
| 16 | $\text{Cl}_2\text{C}=\text{C}(\text{Cl})\text{Cl}$ | 38.342-38.799 | 329 |
| 17° | $\text{O}=\text{C}(\text{Cl})\text{Cl}$ | 35.081, 36.225 | 411 |
| 18° | $\text{O}=\text{C}(\text{R})\text{Cl}$ | 29-31 | 329, 412 |

° Anomalously low Cl^{35} resonance frequencies, from the standpoint of the inductive effect.

b. Fluorine chemical shifts

Values of the chemical shifts of fluorine atoms in several halomethanes⁴¹⁴ are given in Table XXIII. Generally, the greater the participation of the unshared electrons on the fluorine atoms in intramolecular interactions, the less will be their interaction with an externally applied magnetic field, the less, therefore, the internal diamagnetism or nuclear magnetic shielding field, and the lower the applied field, H_c (relative to that for a reference compound, H_r), necessary to produce resonance at a fixed frequency. Of the fluoromethanes included in Table XXIII, the one in which fluorine is least shielded is the one with the fewest fluorine atoms and the most chlorine atoms per molecule, CFCl_3 . This result has been interpreted in terms of a "double-bond mechanism" (19).⁴¹⁴ It would be

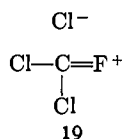

interesting to know accurately the C-F distance in CFCl_3 .

(414) L. H. Meyer and H. S. Gutowsky, *J. Phys. Chem.*, **57**, 481 (1953).

TABLE XXIII
CHEMICAL SHIFTS OF FLUORINE ATOMS IN HALOMETHANES⁴¹⁴

| Compound | $10^6(H_c - H_r)/H_c$ | Compound | $10^6(H_c - H_r)/H_c$ |
|-------------------------|-----------------------|--------------------------|-----------------------|
| CH_3F | +210.0 | CF_3Cl | -36.8 |
| CH_2F_2 | +80.9 | CF_2Cl_2 | -60.4 |
| CHF_3 | +18.2 | CFCl_3 | -76.7 |
| CF_4 | 0.00 | | |

Values of the chemical shifts of fluorine in *para*-substituted fluorobenzenes are interesting. *para* substituents studied and reported F^{19} chemical shifts (in cyclohexane) are⁴¹⁵ OCH_3 , 11.70; F , 6.80; CH_3 , 5.40; SCH_3 , 4.40; Br , 2.60; OCF_3 , 2.25; H , 0.00; CF_3 , -5.05; COCH_3 , -6.10; CN , -8.95; NO_2 , -9.20. The chemical shift is positive when the *para* substituent is a better π -electron donor than hydrogen and negative when it is a better π -electron acceptor.

c. $\text{C}^{13}-\text{F}^{19}$ coupling constants

Carbon-13-fluorine-19 coupling constants for some halomethanes are given in Table XXIV. Broadly speaking, the $\text{C}^{13}-\text{F}^{19}$ coupling constant appears to increase with an increase in the double-bond character of the carbon-fluorine bond,⁴¹⁶ *i.e.*, in the halomethanes the coupling constant generally increases as the number of good leaving groups attached to the carbon atom increases.

TABLE XXIV
 $\text{C}^{13}-\text{F}^{19}$ COUPLING CONSTANTS IN HALOMETHANES

| Compound | $\text{C}^{13}-\text{F}^{19}$ coupling constants, ⁴¹⁶ cps | Compound | $\text{C}^{13}-\text{F}^{19}$ coupling constants, ⁴¹⁶ cps |
|-------------------------|--|--------------------------|--|
| CH_3F | 158 | CF_2Cl_2 | 325 |
| CH_2F_2 | 232 | CFCl_3 | 337 |
| CF_4 | 257 | CF_3I | 334 |
| CF_3Cl | 299 | CF_2Br_2 | 358 |
| CF_3Br | 324 | CFBr_3 | 372 |

d. Acid and base dissociation constants of *p*-halophenols and -amines

Data on acid and base dissociation constants cited by Lucken⁴¹⁸ in support of a fluorine "double-bond mechanism" (19) are given in Table XXV. The expected inductive withdrawal of σ electrons from benzene by fluorine appears to be offset in these molecules by fluorine's tendency to share its (formally) unshared π electrons with the benzene ring.

TABLE XXV
ACID ($K_A \times 10^{11}$) AND BASE ($K_B \times 10^{12}$) DISSOCIATION CONSTANTS OF *p*-HALOPHENOLS AND -AMINES

| | F | Cl | Br | I | H |
|---|-----|------|------|------|------|
| <i>p</i> - $\text{XC}_6\text{H}_4\text{OH}$ | 2.6 | 13.2 | 15.5 | 21.9 | 3.2 |
| <i>p</i> - $\text{XC}_6\text{H}_4\text{NH}_2$ | 120 | 28.8 | 21.9 | 15.1 | 12.6 |

e. Solvolysis rates of α -chloro ethers

Data on the rates of solvolysis of α -chloro ethers cited by Hine and Rosseup⁴¹⁷ in support of an oxygen

(415) R. W. Taft, E. Price, I. R. Fox, I. C. Lewis, K. K. Andersen, and G. T. Davis, *J. Am. Chem. Soc.*, **85**, 3147 (1963).

(416) N. Muller and D. T. Carr, *J. Phys. Chem.*, **67**, 112 (1963).

(417) J. Hine and R. J. Rosseup, *J. Am. Chem. Soc.*, **82**, 6115 (1960).

"double-bond mechanism" are given in Table XXVI. It is believed that these compounds solvolyze by an S_N1 carbonium ion mechanism.^{417,418} The marked decrease in solvolysis rate that occurs in going from a compound that has a single solvolyzable chlorine atom attached to an oxygenated carbon atom (no. 1) to one that has two solvolyzable chlorine atoms attached to the oxygenated carbon atom (no. 2) may be compared with the decrease in length of the carbon-chlorine bond that occurs in going from a compound that has a single chlorine atom attached to an oxygenated carbon atom (Table XV, no. 5) to one that has two chlorine atoms attached to the oxygenated carbon atom (Table XV, no. 3). Similarly, the marked decrease in solvolysis rate that occurs in going from $\text{CH}_3\text{OCH}_2\text{Cl}$ (no. 1) to $\text{ClCH}_2\text{OCH}_2\text{Cl}$ (no. 4) may be compared with a corresponding decrease in the ionic character of the carbon-chlorine bond, as reflected, for example, by an increase in Cl^{35} nuclear quadrupole resonance frequency (Table XXII, no. 14 and 15).

TABLE XXVI
SOLVOLYSIS RATE CONSTANTS OF α -CHLORO ETHERS^{417,418}

| No. | Reactant | $k \times 10^4, \text{sec}^{-1}$ |
|-----|--------------------------------------|----------------------------------|
| 1 | $\text{CH}_3\text{OCH}_2\text{Cl}$ | 1200 |
| 2 | $\text{CH}_3\text{OCHCl}_2$ | 30 |
| 3 | CH_3OCCl_3 | 0.46 |
| 4 | $\text{ClCH}_2\text{OCH}_2\text{Cl}$ | ~ 0.1 |

f. Heats of reaction of polyfluoromethanes and related compounds

Evidence from thermochemical data in support of the view that compounds that contain two or more fluorine atoms, or two or more oxygen atoms, attached to the same carbon atom are stabilized through "double-bond-no-bond resonance" has been discussed by Hine.⁴¹⁹ Less stabilization of this type would be expected for the chlorides and bromides of methane, and much less (if any) is found.⁴¹⁹ Acetyl chloride would be an example of a molecule stabilized by "triple-bond-no-bond resonance" (Tables XV and XX). The Hassel-type intermolecular interactions discussed in section II would be an example of "single-bond-no-bond resonance."¹⁹¹

E. THE METHYL HALIDES AND HYDRIDIC HYDROGEN ATOMS

From the standpoint of the electronegativity-inductive-hybridization model,¹⁰³ the mechanical, electrical, geometrical, and magnetic properties of methyl fluoride are anomalous (Table XXVII). Among the methyl halides, methyl fluoride has the lowest average C-H stretching frequency^{420,421} and the lowest C-H

stretching force constant⁴²¹ but, significantly, the largest hydrogen-halogen interaction constant,⁴²¹ the smallest HCH angle,³²⁰ the largest C-H bond lengths,³²⁰ the smallest proton chemical shift, measured from methane,⁴¹⁴ and a dipole moment^{422,423} that, unlike the dipole moments of the other methyl halides, is less than that of the corresponding hydrogen halide: $\mu(\text{CH}_3\text{F}) < \mu(\text{HF})$, whereas $\mu(\text{CH}_3\text{X}) > \mu(\text{HX})$ for $\text{X} = \text{Cl}, \text{Br}, \text{I}$; also, although $\mu(\text{HF}) > \mu(\text{HCl})$, $\mu(\text{CH}_3\text{F}) < \mu(\text{CH}_3\text{Cl})$.

These facts are consistent with the view that the unshared electrons in methyl fluoride participate in intramolecular interactions of the type below (20a) to a

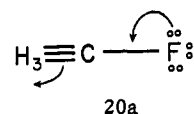

greater extent than dot hose in methyl chloride, bromide, and iodide. Milliken has remarked⁴²⁴ that "[T]he effects of [this type of] isohyperconjugation are doubtless small The writer sees no sufficient reason, however, to assume that they are entirely negligible."

TABLE XXVII
MECHANICAL, ELECTRICAL, GEOMETRICAL, AND MAGNETIC PROPERTIES OF THE METHYL HALIDES

| Property | CH_3F | CH_3Cl | CH_3Br | CH_3I |
|---|-----------------------|------------------------|------------------------|-----------------------|
| C-H stretching frequency, cm^{-1} | | | | |
| Average value ⁴²⁰ | 2976 | 3017 | 3027 | 3030 |
| $(\nu_1 + \nu_4)/2$ ⁴²¹ | 2936 | 2990 | 2996 | 2996 |
| Urey-Bradley force constants, $\text{mdyn}/\text{\AA}$ ⁴²¹ | | | | |
| C-H stretch, K_{CH} | 4.60 | 5.22 | 5.27 | 5.42 |
| $\text{H} \cdots \text{X}$ interaction, F_{HX} | 1.1 | 0.6 | 0.6 | 0.4 |
| Geometry of the methyl group ³²⁰ | | | | |
| HCH angle | 110° | $110^\circ 31'$ | $111^\circ 14'$ | $111^\circ 25'$ |
| C-H bond length (\AA) | 1.097 | 1.0959 | 1.0954 | 1.0958 |
| Dipole moments (D) ^{422,423} | | | | |
| CH_3X | 1.81 | 1.86 | 1.79 | 1.64 |
| HX | 1.91 | 1.08 | 0.79 | 0.38 |
| $\text{C}^{18}\text{-H}$ coupling constant, cps ³²⁰ | 149 | 150 | 152 | 151 |
| Proton chemical shift, from CH_4 ⁴¹⁴ | | | | |
| $(H_o - H_i/H_r) \times 10^6$ | -7.1 | -7.1 | -7.3 | -7.6 |

Larger effects are observed when the methyl group is attached to more powerful electron donors. In CH_3OH the average C-H stretching frequency is 2902 cm^{-1} , in CH_3ONa , 2826 cm^{-1} ,⁴²⁵ simultaneously, the C-O stretching frequency increases, from 1035 to 1074 cm^{-1} .⁴²⁵ In $\text{N}(\text{CH}_3)_3$, where the carbon atom is

(422) A. A. Maryott and F. Buckley, National Bureau of Standards, Circular 537, U. S. Government Printing Office, Washington, D. C., 1953, p 537.

(423) J. W. Smith, "Electric Dipole Moments," Butterworth & Co., Ltd., London, 1955.

(424) R. S. Mulliken in "Conference on Hyperconjugation," V. J. Shiner, Jr., and E. Campaigne, Conference Chairmen, Pergamon Press, New York, N. Y., 1959.

(425) F. H. Seubold, Jr., *J. Org. Chem.*, **21**, 156 (1956).

(418) P. Ballinger, P. B. D. de la Mare, G. Kohnstam, and B. M. Prestt, *J. Chem. Soc.*, 3641 (1955).

(419) J. Hine, *J. Am. Chem. Soc.*, **85**, 3239 (1963).

(420) H. J. Bernstein, *Spectrochim. Acta*, **18**, 161 (1962).

(421) J. Overend and J. R. Scherer, *J. Chem. Phys.*, **33**, 446 (1960).

attached to an atom of the same Pauling electronegativity as chlorine, the C¹³-H coupling constant is only 131 cps.^{320,426}

In contrast to C-H stretching frequencies, Si-H stretching frequencies in compounds of tetravalent silicon, which can expand its octet more easily than can carbon, appear to be controlled by normal inductive effects;^{427,428} mesomeric influences (19) have been judged to play little part.⁴²⁷ On the other hand, Si²⁹-H coupling constants are anomalous, from the viewpoint of inductive effects. In the compounds SiH₃X, X = H, F, Cl, Br, and I, for example, the Si²⁹-H coupling constants are 202.5, 229.0, 238.1, 240.5, and 240.1 cps, respectively.⁴²⁹

Interactions of type 20a should produce hydridic character in hydrogen atoms α to electron donors. It is, in fact, well known that alcohols as well as alkoxide ions can act as reducing agents,⁴³⁰⁻⁴³² that (RO)₃BH⁻ ions are better reducing agents than BH₄⁻,⁴³³ that HCO₂⁻ can transfer hydride ions to both organic^{434,435} and inorganic substrates,⁴³⁶ and that the intermediate RHC(O)₂²⁻ in the Cannizzaro reaction is an effective hydride ion donor.^{434,437} Also, while chlorine increases, fluorine decreases the acidity of substituted nitromethanes when substituted for an α -hydrogen atom.⁴³⁸

F. TILTED METHYL GROUPS

The symmetry axis of a methyl group attached to an oxygen, nitrogen, or sulfur atom appears not to coincide with the C-O, C-N, or C-S bond direction. In methyl alcohol the methyl group's symmetry axis passes between the hydrogen and oxygen atoms of the hydroxyl group and lies at a distance 0.079 Å from the oxygen atom.⁴³⁹ In methylamine the methyl group's symmetry axis passes through the NHH triangle and lies at a distance of 0.091 Å from the nitrogen atom.^{440,441} Always the methyl group appears to be

tilted toward the unshared electrons on the adjacent atom,⁴⁴² by approximately 2.5-3.5° in CH₃OH,⁴³⁹ CH₃-NH₂,^{440,441} CH₃SH,^{443,444} (CH₃)₂S,⁴⁴² and (CH₃)₂O.⁴⁴⁵

A tilt of the methyl group of, for example, methylamine toward the unshared electrons on the nitrogen atom would be expected if the unshared electrons on nitrogen are involved in an intramolecular interaction of the type shown below (20b). This interaction may be

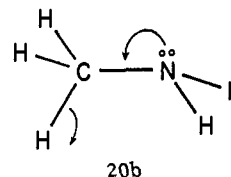

viewed as the first step in the formation of a double bond between the heavy atoms *via trans* elimination of a hydride ion. Methyl groups participating in such interactions should not be exactly symmetrical. Unsymmetrical methyl groups have been suggested for ethyl fluoride,³⁶⁹ acetyl fluoride,³⁷⁹ propylene,⁴⁴⁶ isobutylene,⁴⁴⁷ and (*vide infra*) dimethyl ether.⁴⁴⁵

G. THEORETICAL DESCRIPTIONS

Many of the phrases that have been used to describe intermolecular interactions (section II.E) have also been used to describe intramolecular interactions. Intramolecular interactions of the type 18a,b have been described as intramolecular charge-transfer interactions,⁴⁴⁸ internal neutralization,⁵ no-bond-dative-bond resonance, and the filling of antibonding orbitals.^{192,413,449} They may be described, also, as the internal saturation of residual affinities, secondary Lewis acid-base interactions, intramolecular pair-pocket interactions, internal solvation, the initial step of internal Walden inversions, the limiting case of transannular interactions,⁴⁵⁰ the buildup of secondary coordination shells of electrons, occupancy of the M shell,⁴⁴⁹ and bent intramolecular face-centered bonds. They have been described, also, in terms of hyperconjugation.^{406,424}

The driving force behind these interactions stems, presumably,⁴⁴⁹ from energy-lowering coulombic interactions between nucleophilic and electrophilic centers. Interactions of the type 18a,b may also be promoted, in many instances, by reductions in electron-electron repulsions through the development of anticoincident spin sets,^{210,211,451} particularly, for example, in N₂O₄

- (426) A. W. Douglas, *J. Chem. Phys.*, **45**, 3465 (1966).
 (427) A. L. Smith and N. C. Angelotti, *Spectrochim. Acta*, **15**, 412 (1959).
 (428) H. W. Thompson, *ibid.*, **16**, 238 (1960).
 (429) E. A. V. Ebsworth and J. J. Turner, *J. Chem. Phys.*, **36**, 2628 (1962).
 (430) E. S. Lewis and M. C. R. Symons, *Quart. Rev. (London)*, **12**, 230 (1958).
 (431) N. C. Deno, H. J. Peterson, and G. S. Saines, *Chem. Rev.*, **60**, 7 (1960).
 (432) P. D. Bartlett and J. D. McCollum, *J. Am. Chem. Soc.*, **78**, 1441 (1956).
 (433) H. C. Brown, *J. Chem. Educ.*, **38**, 173 (1961).
 (434) J. Hine, "Physical Organic Chemistry," McGraw-Hill Book Co., Inc., 2nd ed, New York, N. Y., 1962.
 (435) R. Stewart, *Can. J. Chem.*, **35**, 766 (1957).
 (436) J. Halpern and S. M. Taylor, *Discussions Faraday Soc.*, **29**, 177 (1960).
 (437) C. R. Hauser, P. J. Hamrick, Jr., and A. T. Stewart, *J. Org. Chem.*, **21**, 260 (1956).
 (438) H. G. Adolph and M. J. Kamlet, *J. Am. Chem. Soc.*, **88**, 4761 (1966).
 (439) P. Venkateswarlu and W. Gordy, *J. Chem. Phys.*, **23**, 1200 (1955).
 (440) T. Nishikawa, T. Itoh, and K. Shimoda, *ibid.*, **23**, 1735 (1955).
 (441) D. R. Lide, Jr., *ibid.*, **27**, 343 (1957).

- (442) L. Pierce and M. Hayashi, *ibid.*, **35**, 479 (1961).
 (443) R. W. Kilb, *ibid.*, **23**, 1736 (1955).
 (444) T. Kojimo, *J. Phys. Soc. Japan*, **15**, 1284 (1960).
 (445) U. Blukis, P. H. Kasai, and R. J. Meyers, *J. Chem. Phys.*, **38**, 2753 (1963).
 (446) D. R. Lide, Jr., and D. Christensen, *ibid.*, **35**, 1374 (1961).
 (447) L. H. Scharpen and V. W. Laurie, *ibid.*, **39**, 1732 (1963).
 (448) S. Nagakura, *Mol. Phys.*, **3**, 105 (1960).
 (449) J. F. A. Williams, *Trans. Faraday Soc.*, **57**, 2089 (1961).
 (450) A. C. Cope, M. M. Martin, and M. A. McKervey, *Quart. Rev. (London)*, **20**, 119 (1966).
 (451) J. W. Linnett and R. M. Rosenberg, *Tetrahedron*, **20**, 53 (1964).

and related molecules (Table XIV), where arrow, or barb, bending can operate in both directions across the central bond.²⁸⁹

H. GRAPHIC REPRESENTATION

The problem of how best to represent intramolecular interactions has been in the foreground of chemical theory for many years. "In recent times it has become more and more evident," wrote Kermack and Robinson in 1922, "that the graphical formulae employed by organic chemists to represent the constitutions of chemical individuals are expressions which inadequately symbolize the properties of substances, and from time to time efforts have been made to introduce additional systems of notation corresponding with more or less definite theoretical ideas."⁴⁵² The difficulty, Walker remarked in 1923, is that "Partial valencies, augmented valencies, diminished valencies, virtual valencies, represented by lines of various sorts, thick, thin, curved, dotted, etc., all tend to complicate formulae, which lose in obviousness what they gain in definition."⁴⁵³

What the chemist requires in his system of formulation, Walker observes, is something, not which he can *measure*, but which he can *count*—in short, *counters*. "[T]hese counters if they are to be of general practical value must be neither too numerous nor of too great variety."⁴⁵³

In relatively strong inter- and intramolecular interactions, Walker's counters are of two types: (1) the bumps in a molecule's electron cloud, in particular its unshared valence-shell electrons, sometimes electrons in multiple bonds, occasionally electrons in bonds to hydridic hydrogen atoms—in short, the molecule's nucleophilic centers; and (2) the hollows in a molecule's electron cloud, *i.e.*, the lobes of the lowest lying, unoccupied (and generally antibonding) orbitals—in short, the molecule's electrophilic centers. About atoms that have four valence-shell electron pairs, the potentially deepest hollows are generally found opposite orbitals that the atom uses in bonds to good leaving groups. Relatively deep hollows are found, also, opposite the equivalent orbitals that an atom uses in a double bond to oxygen.

The use of curly arrows to represent intramolecular interactions between nucleophilic and electrophilic centers is neither arbitrary nor capricious. Always a curly arrow originates at a nucleophilic center (usually an unshared pair) and terminates at an electrophilic center (*e.g.*, the lobe of an unoccupied antibonding orbital). Always too, for acceptor atoms that cannot easily expand their octets, a curly arrow is conjugated to at least one other curly arrow, that, like the first one,

originates at a nucleophilic center (a shared pair) and terminates at an electrophilic center (a potential site for an unshared pair). (If the ultimate leaving group is a very poor leaving group, arrow(s) conjugate to the first arrow may denote relatively small effects; see below.) Generally, bonds and curly arrows should be assigned to a molecule in such a way that groups designated as entering groups are weaker nucleophiles than the conjugate leaving groups.

Usually, curly arrows are treated as embellishments on conventional graphic formulas. Curly arrows represent secondary (outer-sphere) interactions, not, as do ordinary bonds, primary (inner-sphere) interactions. Generally, curly arrows are introduced only when it is desired to account for *differences* in the properties of two systems, owing to the presence of a set of conjugate donor-acceptor interactions in one system (*e.g.*, CH₃-COCl) but not in the other (*e.g.*, (CH₃)₂CO and CH₃Cl).

I. ADDITIONAL EXAMPLES OF INTRAMOLECULAR INTERACTIONS OF UNSHARED ELECTRONS

1. Molecules and Ions with Abnormally Short Bonds

a. Species isoelectronic with formamide

Compared with the length of the carbon-nitrogen bond in methylamine (1.474 Å), the carbon-nitrogen bond in formamide³⁸¹ is unusually short (1.376 Å). Its shortness has been attributed to resonance (21) or mesomeric (22) effects.⁷

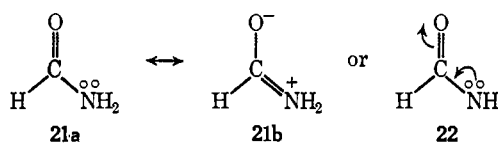

Diagrams 21 and 22 imply that the carbon-oxygen bond in formamide should be longer than a normal carbon-oxygen bond. In fact it is shorter than the carbon-oxygen bond in formaldehyde, acetaldehyde, acetyl cyanide, and propynal (Table XX, no. 1-4 and 6). On the basis of interatomic distances alone, the carbon-oxygen bond in formamide looks like a double bond; at the same time, the carbon-nitrogen bond looks like something between a single bond and a double bond. These facts are summarized in diagram 23.

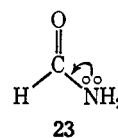

An analogy may be drawn with intermolecular donor-acceptor interactions (section II). When the entering group (here NH₂) is relatively good and the leaving

(452) W. O. Kermack and R. Robinson, *J. Chem. Soc.*, 121, 427 (1922).

(453) J. Walker, *ibid.*, 123, 939 (1923).

group (here O^- ; cf. 22) is relatively poor, the observed distance between the donor and acceptor atoms (N and C) departs from its normal value by a much larger amount than does the contact distance between the acceptor atom and its substituent (C and O).

Over-all bond shortening by lone pairs is particularly pronounced in ozone, the nitrite ion, and the formate ion. Formally, as shown for ozone in diagram 24, the entering group in these instances is the very strong base O^- . Not surprisingly, the bonds in O_3 , NO_2^- ,

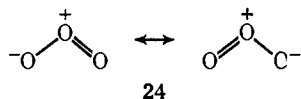

24

and HCO_2^- are in length close to double bonds (Figure 66). These facts may be summarized by some such modification, or corruption, of the conventional Lewis-Pauling graphic formulas of ozone and the nitrite ion as the following (25).

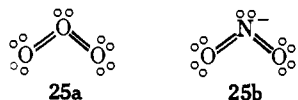

25a

25b

One feature of ozone that, through the years, has remained "puzzling"⁴⁵⁴ is its low dipole moment (0.52 D), which is much lower than expected for the resonating structures (24), but is consistent with structure 25a, where formal charges on the oxygen atoms are zero.

The central atoms in structures 25a and 25b have in the near vicinity of their atomic cores ten electrons; they are, in effect, "pentavalent"—a once, but no longer, fashionable notion for nitrogen. The idea of "pentavalent" oxygen, nitrogen, or carbon atoms is not, however, inconsistent with the molecular orbital formulation of electronic structure. The MO description of the 18-valence-shell-electron species O_3 , NO_2^- , and HCO_2^- might start with a planar network of localized σ molecular orbitals containing two single bonds and five lone-pair orbitals formed from the hybridized s , p_x , and p_y atomic orbitals of the three (heavy) atoms. From the three remaining atomic p orbitals, a , b , a' (perpendicular to the molecular plane) are formed, for the four remaining valence-shell electrons, two delocalized molecular orbitals of the form $a + kb + a'$ and $a - a'$. To exhibit in this description the *mutual disposition* of the last four electrons, the delocalized MO's may be transformed to the equivalent, localized molecular orbitals $2a + kb$ and $2a' + kb$ (section II.E). Each of these localized molecular orbitals corresponds to a localized bond between the central atom and one of its neighbors. Thus, altogether, the MO description places in the bonding regions of the molecules eight electrons and about the central atoms ten electrons, as indicated in 25.

(454) G. M. Phillips, J. S. Hunter, and L. E. Sutton, *J. Chem. Soc.*, 147 (1945).

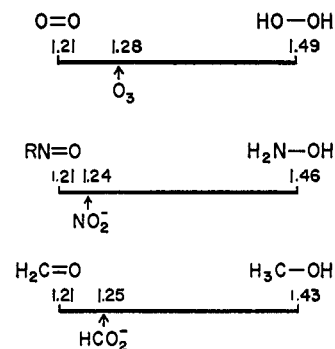

Figure 66.—Bond-length comparisons for O_3 , NO_2^- , and HCO_2^- .

b. Carbonate and nitrate ions

The central atoms in the ions CO_3^{2-} and NO_3^- participate in bonds that, taken as a whole, are, again, unusually short. The C-O distance in CO_3^{2-} (in $CaCO_3$ ⁴⁵⁵) is 1.283 Å, almost as short as the C-O distance in HCO_2^- . The N-O distance in NO_3^- (in $NaNO_3$ ⁴⁵⁶) is 1.212 Å, essentially the same as the N-O double bond distance in HNO (1.212 Å).⁴⁵⁷

c. Species isoelectronic with nitrous oxide

Figure 67 illustrates the fact that the nitrogen-nitrogen distance in nitrous oxide³³⁴ is almost as short as the triple bond in N_2 ; at the same time, the nitrogen-oxygen distance in N_2O is almost as short as a nitrogen-oxygen double bond, even after allowance has been made for the bond-shortening effect of adjacent multiple bonds (section III.B). The end-to-end distance in nitrous oxide is, in fact, about 0.07 Å less than the distance expected for the structure $\bar{N}=N^+=\bar{O}$, about 0.16 Å less than the distance expected for the structure $N\equiv N^+-\bar{O}$, and only about 0.05 Å greater than the distance expected for the nonclassical structure (26).

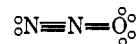

26

This structure accounts, to a first approximation, for the interatomic distances in N_2O and, in placing on the atoms no formal charges, is consistent with the molecule's low dipole moment (0.18 D).

Interatomic distances relevant to a discussion of the bonding in hydrazoic acid²⁸¹ and diazomethane⁴⁵⁸ are summarized in Figures 68 and 69. Evidently, as in formamide, ozone, the nitrite ion, the formate ion, and nitrous oxide, when a molecule or ion contains an atom,

(455) H. Chessin, B. Post, and W. C. Hamilton, *Acta Cryst.*, 18, 689 (1965).

(456) R. L. Sass, R. Vidale, and J. Donohue, *ibid.*, 10, 567 (1957).

(457) F. W. Dalby, *Can. J. Phys.*, 36, 1336 (1958).

(458) P. Cox, L. F. Thomas, and J. Sheridan, *Nature*, 181, 1000 (1958).

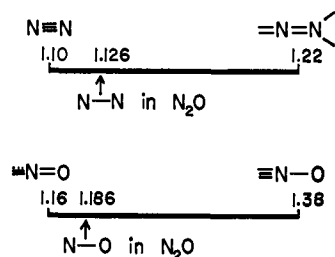

Figure 67.—Bond-length comparisons for nitrous oxide.

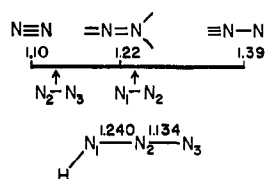

Figure 68.—Bond-length comparisons for hydrazoic acid.

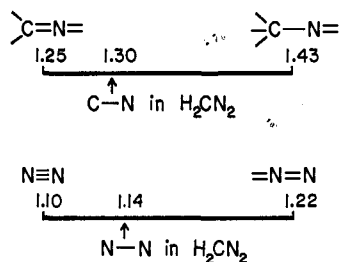
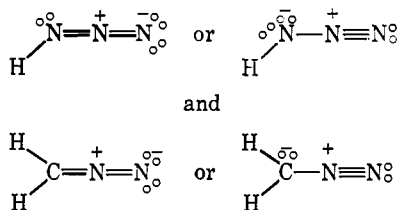
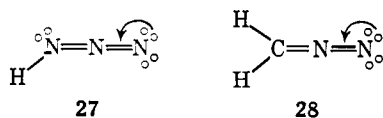

Figure 69.—Bond-length comparisons for diazomethane.

here nitrogen, attached (i) to another atom that in any of the molecule's classical octet structures has a strongly basic lone pair and when, in addition, the first atom is attached (ii) through at least one multiple bond (iii) to poor leaving groups exclusively, as is the case for the central heavy atoms in the structures



then the atom under consideration approaches a "pentavalent" state, as indicated in diagrams 27 and 28.^{458a}



The structure of the fulminate ion, which is iso-electronic with nitrous oxide, hydrazoic acid, and di-

azomethane, may probably be represented, to a first approximation, by the nonclassical structures 29a or 29b. Either representation of the ion is consis-

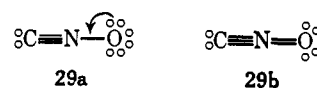

tent with the previous discussion and with the suggestion that in silver fulminate the fulminate ion participates in a three-center silver-carbon-silver bond⁴⁵⁹ (30).

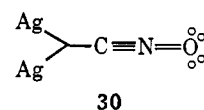

d. Summary

Over-all bond shortening appears to occur in molecules and ions that, in their classical representations, contain "unshared" electrons that can participate in intramolecular donor-acceptor interactions in which (i) the entering group is very good; (ii) the acceptor atom (a small-core atom) has been activated by a multiple bond; and (iii) the only leaving groups are very poor. This effect may be represented, perhaps crudely but usefully, by a *single* arrow or by an *additional* bond. The effect is consistent with, and to some extent offers an explanation for, Pauling's observation that "resonance between two or more structures [often] leads to interatomic distances nearly as small as the smallest of those for the individual structures".⁴⁶⁰

Bond shortening by "unshared" electrons may also help to account for the observation that bond length appears to be relatively insensitive to an assumed variation in bond order when the latter is approximately three.⁴⁶¹ An example is the length of the C-N bond in transition metal cyanides: the length of this bond is a relatively insensitive function of the nature of the metal-carbon bond, across which there may be donor-acceptor interactions between t_{2g} electrons in the transition metal cation and the π antibonding orbitals of the CN group. The "leaving groups" in these interactions are the electrons of the C-N triple bond. But these electrons, if promoted to the status of unshared electrons, would be strongly basic; they are poor leaving groups. In such circumstances the length (and order) of the donor-acceptor bond may change much more than the length (and order) of the acceptor-acceptor substituent bond.

(459) D. Britton and J. D. Dunitz *Acta Cryst.*, 19, 662 (1965).

(460) L. Pauling, *Proc. Natl. Acad. Sci. U. S.*, 18, 293 (1932).

(461) F. A. Cotton, T. G. Dunne, and J. S. Wood, *Inorg. Chem.*, 3, 1495 (1964).

(458a) NOTE ADDED IN PROOF.—Cf. R. Bonaccorsi, C. Petronglo, E. Scrocco, and J. Tomasi, *J. Chem. Phys.*, 48, 1500 (1968).

f. Other examples of over-all bond shortening by unshared electrons

i. Over-Crowded Nitrogen Atoms.—In the *syn*-methyl-diazotate ion⁴⁶² (Figure 70), the nitrogen–nitrogen bond is the same length as the nitrogen–nitrogen double bond in N_2F_2 .²⁸¹ But the nitrogen–oxygen bond in this ion is not a single bond: in length (1.306 Å) it is closer to a double bond (1.212 Å in HNO) than it is to a single bond (1.46 Å in NH_2OH). The nitrogen atom that is involved in these two bonds, which, *taken together*, are relatively short, is attached to an atom (oxygen) that, in the classical Lewis octet structure of the ion, would have in its valence shell strongly basic, unshared electrons. As indicated in Figure 70 by the valence strokes and the curly arrow, the nitrogen atom of the N–O bond appears to have in the immediate vicinity of its kernel somewhat more than eight electrons.

“Over-crowded” nitrogen atoms are also found, in similar environments, in *p*-methoxyindophenol N-oxide,⁴⁶³ dimers of nitroso compounds⁴⁶⁴ (Figure 71), and *meso*-ionic and related compounds (see below), and would be expected in azoxy compounds and dialkyl-nitrosamines.

ii. Over-Crowded Carbon Atoms.—Uracil (Figure 72), is formally isoelectronic with *m*-xylene. The lengths of its ring bonds⁴⁶⁵ are close to those expected for three-electron bonds and are so represented in Figure 72, in the notation of Linnett. But, as the double bonds indicate, the carbon–oxygen bonds are much shorter than single bonds.⁴⁶⁵ Similarly over-crowded carbon atoms have been reported in a phosphorus ylid,⁴⁶⁶ 5-aminotetrazole,⁴⁶⁷ and formamidoxime,⁴⁶⁸ which is isoelectronic with *syn*-methyl-diazotate (Figure 73).

A striking example of “pentavalent” carbon⁴⁶⁹ occurs in the vinylideneamine group, CCN .^{469–471} In, for example, $(CH_3SO_2)_2CCNCH_3$, the heavy-atom skeleton $CCNC$ is linear⁴⁶⁹ (Figure 74). Correspondingly, the bond number of the middle atom of the group CCN is very high:⁴⁶⁹ interatomic distances indicate a C–N triple bond and, very nearly, a C–C double bond.

iii. meso-Ionic Compounds. Compounds that, like nitrous oxide, cannot be satisfactorily represented by any one conventional covalent or polar Lewis octet

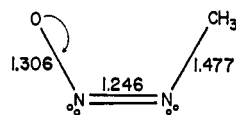

Figure 70.—Structure of the *syn*-methyl-diazotate anion.

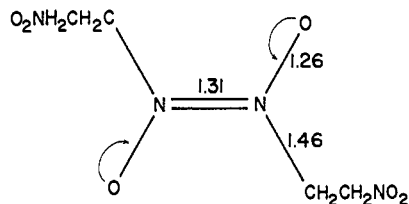

Figure 71.—Structure of the dimer of a nitroso compound.

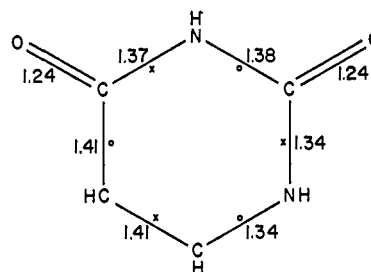

Figure 72.—Uracil.

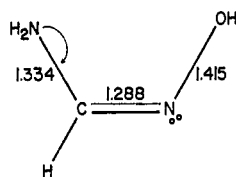

Figure 73.—Formamidoxime.

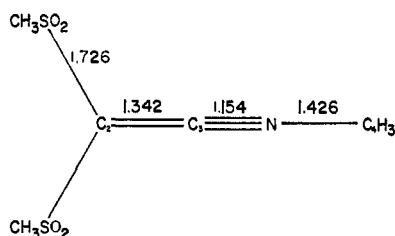

Figure 74.—Structure of $(CH_3SO_2)_2CCNCH_3$.

structure have been called *meso*-ionic compounds.⁴⁷² They often contain five-membered heterocyclic rings with exocyclic oxygen, sulfur, or nitrogen atoms. The mechanism of formation of sydnones,⁴⁷² which have been taken as prototypes of *meso*-ionic compounds, suggests how, to a first approximation, the electronic structures of this class of compounds might be formulated (Figure 75).^{472a} Interatomic distances in Figure

(462) R. Huber, R. Langer, and W. Hoppe, *Acta Cryst.*, **18**, 467 (1965).

(463) C. Romers and B. Hesper, *ibid.*, **20**, 162 (1966).

(464) F. P. Boer and J. W. Turley, *J. Am. Chem. Soc.*, **89**, 1034 (1967).

(465) G. S. Parry, *Acta Cryst.*, **7**, 313 (1954).

(466) A. J. Speziale and K. W. Ratts, *J. Am. Chem. Soc.*, **87**, 5603 (1965).

(467) K. Britts and I. L. Karle, *Acta Cryst.*, **22**, 308 (1967).

(468) D. Hall, *ibid.*, **18**, 955 (1965).

(469) P. J. Wheatley, *ibid.*, **7**, 68 (1954).

(470) R. K. Bullough and P. J. Wheatley, *ibid.*, **10**, 233 (1957).

(471) J. J. Daly, *J. Chem. Soc.*, 2801 (1961).

(472) W. Baker and W. D. Ollis, *Quart. Rev. (London)*, **11**, 15 (1957).

(472a) NOTE ADDED IN PROOF.—A similar model has been proposed by K. Sundaram and W. P. Purcell, *Intern. J. Quantum Chem.*, **2**, 145 (1968).

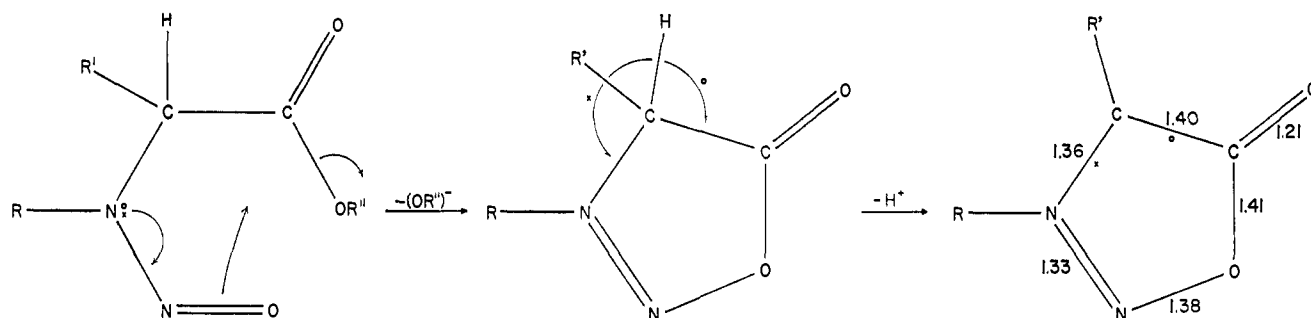

Figure 75.—Formation and model of the electronic structure of sydnone.

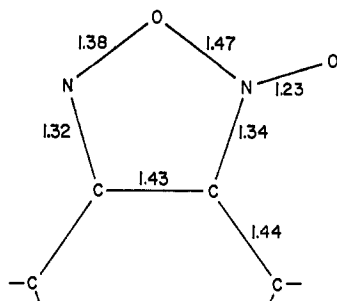

Figure 76.—Structure of one of the five-membered heterocyclic rings in benzotrifuroxan (hexanitrosobenzene).

75 are average values of two recent structural determinations, on a 3-alkyl-⁴⁷³ and 3-*p*-bromophenyl-sydnone.⁴⁷⁴ The formulation of sydnone in Figure 75 overcrowds the carbonyl carbon atom and one of the nitrogen atoms and places on these atoms formal charges of $-1/2$ and $+1/2$, respectively; it is consistent with the observed interatomic distances, the compounds' low basicities,⁴⁷³ their high and intense carbonyl-stretching frequencies,⁴⁷⁵ and the direction and magnitudes of their dipole moments.^{472, 476}

Isoelectronic with the heterocyclic rings in Figure 75 are the three equivalent five-membered heterocyclic rings in benzotrifuroxan (hexanitrosobenzene),⁴⁷⁷ one ring of which is depicted in Figure 76.

2. Molecules with Unusual Physical Properties

a. Structure and barrier to internal rotation of methyl isocyanate

The structure of methyl isocyanate and the barrier to internal rotation of its methyl group, V_3 , have been compared with those of *N*-methylmethylenimine, CH_3NCH_2 ⁴⁷⁸ (Table XXVIII⁴⁷⁹). Methyl isocyanate's

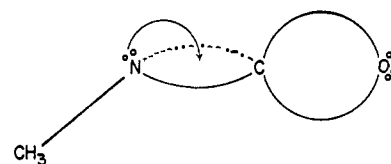

Figure 77.—Intramolecular donor-acceptor interaction in methyl isocyanate.

large CNC bond angle (similar to that of the vinylidene-amine group, Figure 74), its short carbon-oxygen bond (clearly a double bond), and its short carbon-nitrogen bond (nearly a triple bond), together with its low barrier to internal rotation, are consistent with the presence in the molecule of a carbon atom that is

TABLE XXVIII
COMPARISON OF CH_3NCO WITH CH_3NCH_2 ⁴⁷⁸

| | CH_3NCO | CH_3NCH_2 |
|--------------------------------------|-------------------------|---------------------------|
| $r(\text{H}_3\text{C}-\text{N})$, Å | 1.44 (assd) | 1.44 (assd) |
| $r(\text{N}=\text{C})$, Å | 1.19 | 1.30 |
| $\angle \text{CNC}$, deg | 140 | 117 |
| V_3 , cal/mole | 50 ⁴⁷⁹ | 1970 |

over-crowded, owing to an intramolecular interaction of the "unshared electrons" on the nitrogen atom with the interior lobe of the antibonding orbital associated with the lower of the two equivalent orbitals of the carbon-oxygen double bond (Figure 77).

b. Dipole moments of nitrosyl fluoride and trifluoronitrosomethane

The dipole moment of NOF and the components of the dipole moment along the NO and NF bonds⁴⁸⁰ are shown in Figure 78. The origin of the dipole moment vector corresponds to the molecule's center of mass. Noteworthy is the NO bond moment, which points in a direction opposite to that expected from the difference in electronegativity of oxygen and nitrogen.⁴⁸⁰ Its direction is consistent with a mesomeric shift in electron density from oxygen toward fluorine (31).

(473) W. E. Thiessen and W. Hope, *J. Am. Chem. Soc.*, **89**, 5977 (1967).

(474) H. Bärnighausen, F. Jellinek, J. Munnik, and A. Vos, *Acta Cryst.*, **16**, 471 (1963).

(475) J. Fugger, J. M. Tien, and I. M. Hunsberger, *J. Am. Chem. Soc.*, **77**, 1843 (1955).

(476) R. A. W. Hill and L. E. Sutton, *J. Chem. Soc.*, 746 (1949).

(477) H. H. Cady, A. C. Larson, and D. T. Cromer, *Acta Cryst.*, **20**, 336 (1966).

(478) K. V. L. N. Sastry and R. F. Curl, Jr., *J. Chem. Phys.*, **41**,

77 (1964).

(479) R. F. Curl, Jr., V. M. Rao, K. V. L. N. Sastry, and J. A. Hodgeson, *ibid.*, **39**, 3335 (1963).

(480) D. W. Magnuson, *ibid.*, **19**, 1071 (1951).

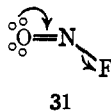

Such an interaction is also consistent with the relatively short N-O bond in NOF (1.13 Å compared with 1.212 Å in HNO) and with the molecule's relatively long N-F bond (section III.D.13).

Another nitroso compound with an unusual dipole moment is CF₃NO; its moment is probably less than 0.31 D.⁴⁸¹ This low moment has been attributed to contributions from an ionic form (N≡O)⁺CF₃⁻.⁴⁸¹ Significantly, the F¹⁹ magnetic resonance in CF₃NO occurs at an unusually high field, perhaps higher than that of any other covalent compound containing the CF₃ group.⁴⁸¹

c. Bending vibrations of diazomethane, ketene, and carbon suboxide

The carbon-carbon bond in ketene, H₂C=C=O (1.314 Å⁴⁸²), appears to be slightly longer—despite the presence of the electronegative oxygen atom (section III.B)—than the carbon-carbon bond in allene, H₂C=C=CH₂ (1.308 Å⁴⁸³). This “anomaly” may be viewed as another example of bond lengthening by unshared electrons (32). (In ketene's planar configuration, the migration of electrons from oxygen toward the carbon atom of the methylene group need not occur *via* a displacement of *coincident pairs* (32b).)

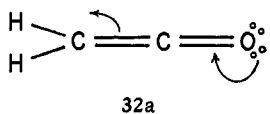

or, more fully

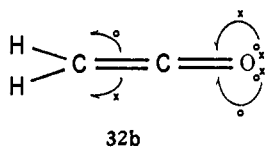

Diagram 32a represents the first step in the thermal decomposition of ketene into carbon monoxide and singlet methylene. It implies, as found,⁴⁸⁴⁻⁴⁸⁸ that the out-of-plane bending force constant of the CH₂ group in ketene and, also, in isoelectronic diazomethane, is unusually low (Table XXIX).

(481) J. E. Boggs, D. Coffey, Jr., and J. C. Davis, Jr., *J. Phys. Chem.*, **68**, 2383 (1964).

(482) A. P. Cox, L. F. Thomas, and J. Sheridan, *Spectrochim. Acta*, **15**, 542 (1959).

(483) D. R. Eaton and H. W. Thompson, *Proc. Roy. Soc. (London)*, **A250**, 39 (1959).

(484) C. B. Moore and G. C. Pimentel, *J. Chem. Phys.*, **38**, 2816 (1963).

(485) C. B. Moore, *ibid.*, **39**, 1884 (1963).

(486) C. B. Moore, and G. C. Pimentel, *ibid.*, **40**, 329 (1964).

(487) C. B. Moore and G. C. Pimentel, *ibid.*, **40**, 342 (1964).

(488) C. B. Moore and G. C. Pimentel, *ibid.*, **40**, 1529 (1964).

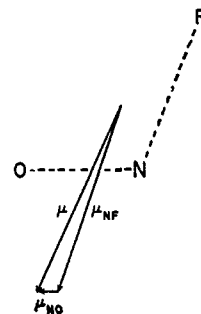

Figure 78.—Dipole moment of NOF and components of the dipole moment along the NO and NF bonds.

Diagram 32a implies also that, other things nearly equal, the CH₂ out-of-plane bending force constant in a molecule should be lower the more basic the electrons conjugated to the double bond of the methylene group. In passing through the compounds listed in Table XXIX, from top to bottom, the electrons in question are: none; the electron pair of one C-H bond of one methyl group (which, however, may be tending to tilt in the wrong direction; see later); unshared electrons on a Cl atom; the electron pairs of two C-H bonds of two methyl groups; unshared electrons on two Cl atoms; the electron pairs of two well-placed, methylene C-H bonds; unshared electrons on an O atom; unshared electrons on an N atom.

TABLE XXIX

OUT-OF-PLANE BENDING FORCE CONSTANTS OF CH₂ GROUPS⁴⁸⁹

| Molecule | Force constant, m dyn Å rad ⁻¹ |
|--|---|
| CH ₂ CH ₂ | 0.23 |
| CH ₂ CHCH ₃ | 0.215 |
| CH ₂ CHCl | 0.21 |
| CH ₂ C(CH ₃) ₂ | 0.20 |
| CH ₂ CCl ₂ | 0.195 |
| CH ₂ CCH ₂ | 0.18 |
| CH ₂ CO | 0.086 |
| CH ₂ NN | 0.027 |

The implications of diagram 32a regarding the magnitudes of the first and second derivatives of the molecular dipole moment with vibrational normal coordinates are consistent with the unusual intensities and anharmonicities observed in the infrared spectra of ketene and diazomethane⁴⁸⁸ and, generally, with the theory of the enhancement of infrared intensities, in such systems as carbon dioxide and nitrous oxide,⁴⁸⁹⁻⁴⁹¹ acyl halides,⁴⁹² and charge-transfer complexes^{493,494} (including hydrogen bonds⁴⁹⁴) by an “electron-vibration” mechanism.^{267,494,495}

(489) A. M. Thorndike, *ibid.*, **15**, 868 (1947).

(490) D. Z. Robinson, *ibid.*, **19**, 881 (1951).

(491) W. B. Person and L. C. Hall, *Spectrochim. Acta*, **20**, 771 (1964).

(492) J. E. Katon and W. R. Fairheller, Jr., *J. Chem. Phys.*, **44**, 144 (1966).

(493) E. E. Ferguson and F. A. Matsen, *ibid.*, **29**, 105 (1958).

(494) H. B. Friedrich and W. B. Person, *ibid.*, **44**, 2161 (1966).

(495) W. D. Jones and W. T. Simpson, *ibid.*, **32**, 1747 (1960).

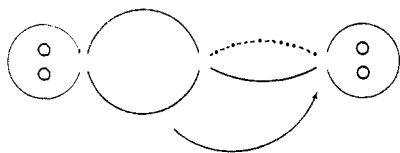
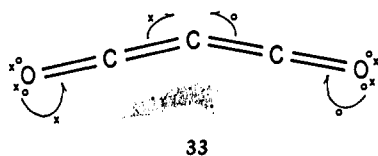

Figure 79.—Model of the low central-atom bending force constant of C_3 .

The central-carbon bending fundamental of carbon suboxide, C_3O_2 , forms an interesting comparison with the CH_2 out-of-plane vibrations of ketene and diazomethane. Like the latter vibrations, its frequency is unusually low: estimated from an entropy study,⁴⁹⁶ $61.6 \pm 2.6 \text{ cm}^{-1}$; observed in the gas,⁴⁹⁷ 63 cm^{-1} ; in the liquid, 72 cm^{-1} , corresponding to a force constant of $0.051 \text{ mdyn}/\text{\AA}$.^{498,499} The intensity of the vibration, however, is very low also.^{497,498} These observations are consistent with an "electron-vibration" mechanism in which electronic charge migrates from both oxygen atoms toward the central carbon atom as the molecule bends (33). In C_3S_2 , where the unshared electrons are



less basic than those in C_3O_2 , the central-atom bending frequency, even despite the increase in mass, is 94 cm^{-1} , higher than that for C_3O_2 ; the corresponding force constant is $0.088 \text{ mdyn}/\text{\AA}$.⁴⁹⁹

d. Bending vibrations of some electron-deficient molecules

The linear, electron-deficient molecule C_3 has a remarkably low central-atom bending force constant⁵⁰⁰ (Table XXX). This small force constant may be rationalized in terms of intramolecular donor-acceptor interactions between electrons in the carbon-carbon double bonds and vacant orbitals (deep "pockets") on the terminal carbon atoms (Figure 79). (For simplicity, Figure 79 is drawn as if the two spin sets in C_3 were coincident.) In a highly bent molecule, this interaction would become a carbon-carbon-carbon three-center bond.

As the vacant orbitals on the terminal atoms become occupied, through electronic excitation (no. 2, Table XXX), or through the addition of more electrons to the system (no. 3-9, Table XXX), the molecule becomes

(496) L. A. McDougall and J. E. Kilpatrick, *J. Chem. Phys.*, **42**, 2311 (1965).

(497) F. A. Miller, D. H. Lemmon, and R. E. Witkowski, *Spectrochim. Acta*, **21**, 1709 (1965).

(498) W. H. Smith and G. E. Leroi, *J. Chem. Phys.*, **45**, 1767 (1966).

(499) W. H. Smith and G. E. Leroi, *ibid.*, **45**, 1784 (1966).

(500) L. Gausset, G. Herzberg, A. Lagerqvist, and B. Rosen, *Discussions Faraday Soc.*, **35**, 113 (1963).

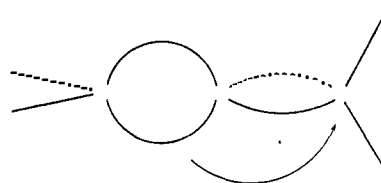

Figure 80.—Model for the discussion of the central-atom bending force constants of allene and carbon dioxide.

stiffer. Stiffest of all are the 16-electron molecules N_2O and CO_2 .⁴⁹⁹ In these molecules the primary orbitals on the terminal atoms are fully occupied. The interesting fact⁴⁹⁹ that allene has a lower central-atom bending force constant than carbon dioxide may be understood in terms of the intramolecular interaction shown in Figure 80. In allene, the relatively shallow internal pockets toward which the arrow points are vacant. In carbon dioxide, whose spin sets, owing to the absence of the extranuclear protons, are angularly anticoincident, the pockets for one spin set are occupied by electrons of the other spin set.

TABLE XXX

CENTRAL-ATOM BENDING FREQUENCIES AND FORCE CONSTANTS FOR SOME LINEAR MOLECULES⁴⁹⁹

| No. | Molecule | No. of valence-shell electrons | Central bending frequency, cm^{-1} | Force constant, $\text{mdyn}/\text{\AA}$ |
|-----|-------------------|--------------------------------|---|--|
| 1 | $C_3(^1\Sigma_g)$ | 12 | 63 | 0.0047 |
| 2 | $C_3(^1\Pi_u)$ | 12 | 308 | 0.11 |
| 3 | CCN | 13 | 325 | 0.15 |
| 4 | CCO | 14 | 381 | 0.18 |
| 5 | NCN | 14 | 423 | 0.22 |
| 6 | BO_2 | 15 | 464 | 0.26 |
| 7 | NCO | 15 | 539 | 0.37 |
| 8 | NNO | 16 | 589 | 0.49 |
| 9 | CO_2 | 16 | 667 | 0.57 |
| 10 | C_3H_4 | 16 | 354 | 0.18 |

e. Structures of O_2F_2 , $N_2(CF_3)_4$, and related molecules

In structures that have two donor atoms attached to the same atom, $\ddot{A}-B-\ddot{C}$, the direction of the dominant donor-acceptor interaction generally will be from the better to the poor donor atom, particularly if, as is usually the case, the better donor is the poorer leaving group. To many obvious examples of this principle, which has been widely applied in the previous discussion, may be added the molecule O_2F_2 . O_2F_2 has a remarkably short O-O distance of 1.217 \AA , almost as short as the O-O distance of 1.208 \AA in molecular oxygen.⁵⁰¹ O_2F_2 has, also, the longest O-F bond reported for any covalent molecule, 1.575 \AA ;⁵⁰¹ the O-F distance in OF_2 , for example, is 1.39 \AA , and O_2F_2 has an unusually large O-F bond moment, possibly four times larger than that in OF_2 .⁵⁰¹ Clearly the synergistic interactions indicated by the curly barbs

(501) R. H. Jackson, *J. Chem. Soc.*, 4585 (1962).

TABLE XXXI
TRENDS IN BOND LENGTHS IN MOLECULES ISOELECTRONIC WITH CH₄, C₂H₆, SiH₄, AND CH₃SiH₃^a

| H and CH ₃ Bonded to First-Row Elements (molecules isoelectronic with methane and ethane) | | | |
|---|----------------------------------|--------------------------|---------------------|
| 1. H-CH ₃ | H-NH ₂ | H-OH | H-F |
| 1.091.....(-0.077)..... | 1.014.....(-0.056)..... | 0.9584.....(-0.041)..... | 0.9175 |
| ⋮ | ⋮ | ⋮ | ⋮ |
| (0.443) | (0.460) | (0.469) | (0.468) |
| ⋮ | ⋮ | ⋮ | ⋮ |
| 1.534.....(-0.060)..... | 1.474.....(-0.047)..... | 1.427.....(-0.042)..... | 1.385 |
| 2. CH ₃ -CH ₃ | CH ₃ -NH ₂ | CH ₃ -OH | CH ₃ -F |
| H and CH ₃ Bonded to Second-Row Elements (molecules isoelectronic with silane and methylsilane) | | | |
| 3. H-SiH ₃ | H-PH ₂ | H-SH | H-Cl |
| 1.4798.....(-0.065)..... | 1.415.....(-0.080)..... | 1.335.....(-0.061)..... | 1.2744 |
| ⋮ | ⋮ | ⋮ | ⋮ |
| (0.3870) | (0.443) | (0.483) | (0.510) |
| ⋮ | ⋮ | ⋮ | ⋮ |
| 1.8668.....(-0.009)..... | 1.858.....(-0.040)..... | 1.8177.....(-0.034)..... | 1.784 |
| 4. CH ₃ -SiH ₃ | CH ₃ -PH ₂ | CH ₃ -SH | CH ₃ -Cl |
| NH ₂ , OH, and F Bonded to First-Row Elements (molecules isoelectronic with ethane) | | | |
| 5. NH ₂ -CH ₃ | NH ₂ -NH ₂ | NH ₂ -OH | NH ₂ -F |
| 1.474.....(0.00)..... | 1.47.....(-0.01)..... | 1.46 | ... |
| 6. HO-CH ₃ | HO-NH ₂ | HO-OH | HO-F |
| 1.427.....(+0.03)..... | 1.46.....(+0.01)..... | 1.47 | ... |
| 7. F-CH ₃ | F-NH ₂ | (F-OH) | F-F |
| 1.385 | ... | ... | 1.4177 |
| | | | 1.435 |

^a Bond lengths in angstroms;^{281, 334} bond-length differences in parentheses.

in Figure 81 have gone nearly to completion;^{502, 503} the O₂F₂ molecule could be described almost as well as a donor-acceptor complex between an oxygen molecule (the donor) and two fluorine atoms.

Such intramolecular interactions (Figure 81) should be important, unless inhibited sterically, in any compound R- $\overset{\cdot}{A}$ - $\overset{\cdot}{B}$ -R' that has good donor atoms, oxygen or nitrogen, at A and B and good leaving groups at R and R'. Not many structures of compounds of this type have been determined. *trans*-N₂F₂ exists and, while its N-N distance (1.25 ± 0.02 Å) is not unusually short, the N-F distance (1.44 ± 0.04 Å) does appear to be longer than normal.²⁸¹ *cis*-N₂F₂ has been judged to have a slightly shortened N-N bond (1.218 ± 0.005 Å)⁵⁰⁴ and its N-F distance (1.384 ± 0.01 Å) is about 0.04 Å longer than the length of an olefinic C-F bond. Esters of hyponitrous acid, RONNOR', are well known, of course, to decompose readily to nitrogen and two free radicals.⁵⁰⁵

The structure of N₂(CF₃)₄ is interesting in several respects.⁵⁰⁶ Its notably short,⁵⁰⁶ and thermally stable,⁵⁰⁷

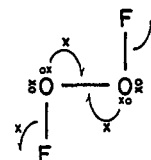

Figure 81.—Model of the electronic structure of dioxygen difluoride.

N-N bond (1.40 ± 0.02 Å), nearly flat -N< pyramid ($\angle \text{CNC} = 121.2 \pm 1.5^\circ$, $\angle \text{NNC} = 119.0 \pm 1.5^\circ$), and dihedral angle between opposite -N(CF₃)₂ groups of approximately 90° are consistent with an interaction across the N-N bond similar to that in Figure 81, in which one barb (to achieve anticoincidence) comes in at 90° to the other barb. Both interactions may be augmented by steric repulsions.⁵⁰⁶

In N₂F₄, on the other hand, where there are two donor atoms attached to each nitrogen atom, the central bond, like that in N₂O₄, is relatively weak.⁵⁰⁸

f. Bond lengths in hydrazine, hydroxylamine, and hydrogen peroxide

The lengths of bonds to H and CH₃ from two sets of isoelectronic substituents, CH₃, NH₂, OH, F, and SiH₃, PH₂, SH, Cl, are compared in Table XXXI. These trends may be noted.

(502) J. W. Linnett, *J. Chem. Soc.*, 4663 (1963).

(503) J. W. Linnett, *Am. Sci.*, 52, 459 (1964).

(504) R. L. Kuczkowski and E. B. Wilson, Jr., *J. Chem. Phys.*, 39, 1030 (1963).

(505) N. V. Sidgwick, "The Organic Chemistry of Nitrogen," revised by I. T. Miller and H. D. Springall, 3rd ed, Oxford University Press, London, 1966, p 83.

(506) L. S. Bartell and H. K. Higginbotham, *Inorg. Chem.*, 4, 1346 (1965).

(507) J. A. Young and R. D. Dresdner, *J. Org. Chem.*, 28, 833 (1963).

(508) C. B. Colburn and F. A. Johnson, *J. Chem. Phys.*, 33, 1869 (1960).

(i) For bonds to H and CH₃ (series 1-4), concentration of nuclear charge (*e.g.*, the change from the substituent NH₂ to OH, or from PH₂ to SH) leads, as expected, to a decrease in bond length. For each unit increase in nuclear charge, the decrease in bond length is *ca.* 0.04-0.08 Å. (The exceptional case, CH₃-SiH₃ to CH₃-PH₂, has been discussed elsewhere.²⁰⁷)

(ii) Decreases in bond length with increasing charge concentration are greater for bonds to H than for bonds to CH₃. This difference is consistent with the rule that carbon atoms tend to concentrate their p character in bonds toward electronegative substituents (section III.B). Consequently, as observed, the hydrogen-methyl difference generally increases with increasing concentration of charge in the nucleus of the substituent atom.

(iii) The increase in the hydrogen-methyl difference with increasing concentration of charge is less for first- than for second-row elements. Even allowing for differences in core sizes, a C-F bond, *e.g.*, is relatively short compared with a C-Cl bond. This difference may reflect, in part, the particular tendency of unshared electrons on atoms of first-row elements to participate in bond-shortening interactions (20b).

(iv) Charge concentration has remarkably little effect on the lengths of bonds to NH₂ (series 5); that is to say, the bonds H₂N-NH₂ and H₂N-OH are unusually long, particularly H₂N-OH.

(v) Charge concentration leads in some cases to an unexpected increase in the length of bonds to OH and F (series 6 and 7). Most notable is the bond HO-OH; it is over 0.2 Å longer than expected.

As a consequence of trends i, iv, and v, charge concentration produces an irregular, and at first sight seemingly inexplicable, variation in bond length in the series of isoelectronic molecules CH₃-CH₃, NH₂-NH₂, HO-OH, F-F, for which the bond lengths are, respectively, 1.534, 1.47, 1.47, 1.42 Å. It is difficult, if not impossible, to account for such "trends" solely in terms of lone-pair-lone-pair repulsions, or nuclear-nuclear repulsions, or atom rehybridization.

Another factor to consider is the decrease that would occur in intraatomic electron-electron repulsions if the bonds in question were to dissociate.^{210,211,451} Taking as an approximate measure of this factor the increase in number of anticoincident electron pairs produced in a radical on dissociation, not counting the bonding pair itself, and taking protonated pairs as coincident before and after dissociation, one obtains for the radicals under consideration these numbers: CH₃, 0; NH₂, 1; OH, 2; F (which starts with three partially anticoincident pairs), ~1. Owing to the operation of the exclusion effect in bonding regions, the bond-lengthening effect of intraatomic electron-electron repulsions will be, at least in part, a cooperative effect: production of anticoincidence in an atom at one end of

a bond will be enhanced if anticoincidence can also occur relatively easily in the atom at the other end of the bond. This consideration suggests taking, as a simple, approximate measure of the bond-lengthening effect of intraatomic electron-electron repulsions, the *product* of the numbers arrived at above for the individual radicals (Table XXXII).

TABLE XXXII
INTRAATOMIC ELECTRON-ELECTRON-REPULSION
BOND-LENGTHENING-EFFECT PARAMETERS

| Series ^a | CH ₃ -CH ₃ | CH ₃ -NH ₂ | CH ₃ -OH | CH ₃ -F |
|---------------------|---------------------------------------|---------------------------------------|--------------------------|-------------------------|
| 2 | 0 | 0 | 0 | 0 |
| 5 | NH ₂ -CH ₃ 0 | NH ₂ -NH ₂ 1 | NH ₂ -OH 2 | NH ₂ -F 1 |
| 6 | HO-CH ₃ 0 | HO-NH ₂ 2 | HO-OH 4 | HO-F 2 |
| 7 | F-CH ₃ 0 | F-NH ₂ 1 | F-OH 2 | F-F 1 |
| (8) | CH ₃ -CH ₃ 0 | NH ₂ -NH ₂ 1 | HO-OH 4 | F-F 1 |

^a See Table XXXI.

The intraatomic electron-electron-repulsion bond-lengthening-effect parameters tabulated in Table XXXII follow, approximately, the main features of the trends in bond lengths displayed in Table XXXI. When the bond-lengthening parameter does not change through a series, the bond-shortening effect of charge concentration is observed (series 2). When the bond-lengthening parameter increases by one unit at each step in a series, it nearly cancels the charge concentration effect (series 5). When it increases by two units at each step, it tends to overwhelm the charge concentration effect (series 6).

Since protonation of an electron cloud decreases angular anticoincidence, hydrazine, hydroxylamine, and particularly hydrogen peroxide should be weaker Brønsted bases than might otherwise be expected, without necessarily being correspondingly weaker nucleophiles toward substrates other than Brønsted acids. Data that support this supposition have been discussed, in a different context, by Edwards and Pearson.⁵⁰⁹

3. Hard and Soft Acids and Bases

When a pair of electrons is held in a σ bond between two atomic cores that differ widely in size (one core being relatively small, say 0.5 Å in radius or less, as in the halogens, Se, S, O, Sb, As, P, and N; the other core being relatively large, say 0.5 Å or more, as in most metal atoms), the bonding pair will be held more tightly to one core than to the other. A bond of this type is generally highly polar and relatively labile. On breaking, both bonding electrons generally remain attached to the smaller atomic core. The smaller core

(509) J. O. Edwards and R. G. Pearson, *J. Am. Chem. Soc.*, **84**, 16 (1962).

TABLE XXXII
ORBITAL MODEL OF HARD AND SOFT ACIDS AND BASES

| | Role in donor-acceptor interactions | | |
|------|-------------------------------------|--|---|
| | Primary role (Lewis interaction) | Secondary role (GFBCADP ^a interaction) | |
| | | "Hard" (Class a; lithophile) | "Soft" (Class b; chalcophile) |
| Acid | σ acceptor | π acceptor (Class a; lithophile) | π donor (Class b; chalcophile) |
| | | Si ⁴⁺ Mg ²⁺ RCO ⁺ | Cu ⁺ Hg ²⁺ I ₂ |
| Base | σ donor | π donor | π acceptor |
| | | H ₂ O RO ⁻ F ⁻ | R ₃ P CO S ₂ O ₈ ²⁻ |

^a Goldschmidt-Fajans-Bjerrum-Scharzenbach-Ahrland, Chatt, Davies-Pearson.

is usually called the electron donor, or Lewis base; the larger core the electron acceptor, or Lewis acid.

Already, in 1922, it was recognized by Goldschmidt^{510,511} (in his classification of elements as chalcophile (Cu, Ag, Zn, Hg) and lithophile (Li, Na, K, Rb, Cs, Be, Mg, Ca, Sr, Ba)) and later, by, for example, Fajans,⁵¹² Bjerrum,⁵¹³ Schwarzenbach,⁵¹⁴ and Ahrland, Chatt, and Davies,⁵¹⁵ that, in addition to primary, Lewis, σ -type donor-acceptor interactions, two atoms may interact *via* secondary, π -type, electron donor-acceptor interactions, for which (in part) Pearson has introduced the terms "hard" and "soft"^{516,517} (Table XXXIII). These secondary π - π donor-acceptor interactions are sometimes represented by curly arrows.

In Pearson's terminology, hard acids prefer to associate with hard bases, soft acids with soft bases⁵¹⁷ (Table XXXIII). A disadvantage of this terminology, namely that coordination of a very soft ligand by a soft acceptor may make the acceptor hard,⁵¹⁸ would disappear if a single adjective were used to denote secondary donor capability, whether of an acid or a base, and another adjective were used, similarly, for secondary acceptor capability. One might speak, for example, of " π -donor" (" π -d") and " π -acceptor" (" π -a") acids; or simply of "donor acids" ("d-acids") and "acceptor acids" ("a-acids"); or of " $\sigma_a\pi_d$ " and " $\sigma_a\pi_a$ " reagents. But even if simpler to write, if not to say, these alternatives may tie the terminology too closely to a theoretical (and therefore provisional) model, for the orbital model of Table XXXIII does not

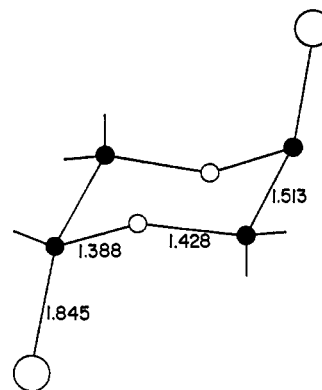

Figure 82.—Structure of *trans*-2,5-dichloro-1,4-dioxane in the solid phase.

cover all types of interatomic interactions. The hydride ion, *e.g.*, is classified as a soft base, and hydrogen-bonding molecules are classified as hard acids, yet these reagents do not have vacant π -type orbitals, nor have they, however, occupied π orbitals, which might interfere, sterically, with π -type electrons in soft acids and hard bases.

J. STERIC REQUIREMENTS

There exists a growing body of structural data that suggests that an intramolecular donor-acceptor interaction of the type 18a is favored when the lone pair on atom C approaches a small-core acceptor atom B (*e.g.*, carbon) on the side opposite the leaving group, *i.e.*, when the lone pair and the leaving group are *trans* to each other.

1. Structures of Halo-1,4-dioxanes

In the dihalodioxanes whose structures have been determined, the dioxane rings have the chair form with normal valence angles. As a rule, the halogen atoms occupy axial positions.⁵¹⁹ In that position, they are *trans* to axial lone pairs on oxygen atoms. That there is an intramolecular interaction between a halogen atom and the axial (*i.e.*, *trans*), but not the equatorial (*i.e.*, *gauche*), lone pair of a neighboring oxygen atom is further indicated by these facts. In *trans*-2,5-dichloro-1,4-dioxane the C-O bonds are not equivalent⁵¹⁹ (Figure 82). Bond C(1)-O (1.388 Å), but not bond C(2)-O (1.428 Å), is significantly shorter than the C-O distances in methyl alcohol (1.428 Å) and dimethyl ether (1.410 Å). At the same time the C-Cl bond (1.845 Å) is significantly longer⁵¹⁹ than the C-Cl distance in methyl chloride (1.784 Å). On the other hand, *cis*-2,3-dichloro-1,4-dioxane has an equatorial Cl atom, which is not *trans* to any lone pairs, and the corresponding C-Cl distance (1.781 Å) is normal.⁵²⁰

(510) B. Mason, "Principles of Geochemistry," John Wiley and Sons, Inc., New York, N. Y., 1952.

(511) V. M. Goldschmidt, "Geochemistry," Oxford University Press, London, 1954.

(512) K. Fajans and G. Joos, *Z. Physik.*, **23**, 1 (1924).

(513) J. Bjerrum, *Chem. Rev.*, **46**, 381 (1950).

(514) G. Schwarzenbach, *Experientia, Suppl.*, **5**, 162 (1956).

(515) S. Ahrland, J. Chatt, and N. R. Davies, *Quart. Rev. (London)*, **12**, 265 (1958).

(516) R. G. Pearson, *J. Am. Chem. Soc.*, **85**, 3533 (1963).

(517) R. G. Pearson, *Science*, **151**, 172 (1966).

(518) S. Ahrland, *Chem. Eng. News*, 93 (May 31, 1965).

(519) C. Altona, C. Knobler, and C. Romers, *Acta Cryst.*, **16**, 1217 (1963).

(520) C. Altona and C. Romers, *ibid.*, **16**, 1225 (1963).

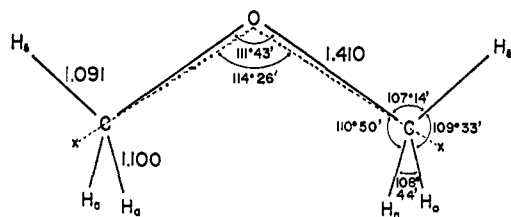

Figure 83.—Structure of dimethyl ether in the gas phase.

2. Structure of Dimethyl Ether

The structure of dimethyl ether⁴⁴⁵ is noteworthy in several respects. Its methyl groups are staggered with respect to the opposite C–O bonds (Figure 83). This arrangement places two hydrogen atoms of each methyl group (hydrogen atoms H_a) *trans* to lone pairs on the oxygen atom. It is found, correspondingly, that the C– H_a bonds (1.100 ± 0.005 Å) are probably slightly longer than the C– H_b bonds (1.091 ± 0.007 Å). When the leaving group *trans* to a lone pair on an ether oxygen atom is hydrogen, rather than chlorine, the bond-lengthening effect of the lone pair, while small (as expected), is apparently discernible.

Further evidence of weak intramolecular donor-acceptor interactions in dimethyl ether are found in its bond angles. The angles OCH_b ($107^\circ 14' \pm 35'$) are smaller than the angles OCH_a ($110^\circ 50' \pm 20'$); on the other hand, the nonbonded $H_a \cdots H_a$ and $H_a \cdots H_b$ distances within a methyl group differ from each other by less than 0.002 Å. Thus, the angle formed by the two carbon atoms and the centers of mass of the hydrogens of the methyl groups ($114^\circ 26'$) is larger than the COC angle ($111^\circ 43'$). The C–O bond appears to be "bent."⁴⁴⁵ It is as if each methyl group had glided, almost as a rigid body, about its C–O bond, toward the lone pairs on oxygen, forming thereby two weak, bent, intramolecular pair-pocket bonds.

Alternatively, it might be supposed that the source of the "bent bonds," and attendant structural features, are methyl-methyl repulsions.⁴⁴⁵ This model is applicable to dimethyl ether, but not to methyl alcohol.

The donor-acceptor interaction model implies that the C–O bonds of dimethyl ether should be shorter than normal (a normal C–O bond being one across which there are no donor-acceptor interactions). The methyl-methyl repulsion model suggests that these bonds might be longer than normal. Neither model offers an obvious explanation for the fact that the C–O distance in dimethyl ether (1.410 Å) is less than the C–O distance in methyl alcohol (1.428 Å).

3. Structures and Basicities of Cyclic Ethers

The C–O bond in ethylene oxide (1.436 Å) is abnormally long. Thus, whereas the C–C bond in isoelectronic cyclopropane (1.524 Å) is about 0.01 Å shorter than the C–C bond in ethane, the C–O bond

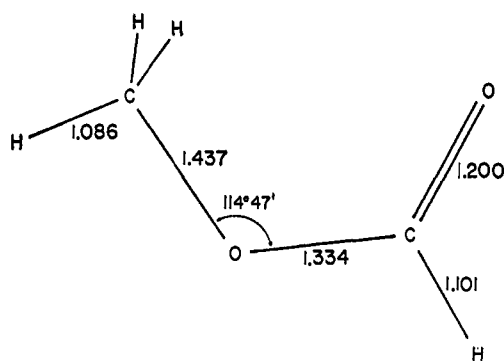

Figure 84.—Structure of methyl formate in the gas phase.

in ethylene oxide is nearly 0.01 Å longer than the C–O bond in methyl alcohol and over 0.02 Å longer than the C–O bond in dimethyl ether. The C–N bond in ethylenimine (1.488 Å), similarly, is longer, not shorter, than the C–N bond in methylamine.

Before the unusual length of these bonds is attributed to the absence of multiple-bond character, owing to the fact that the unshared electrons on oxygen and nitrogen in ethylene oxide and ethylenimine are *trans* to no bonds, it should be noted that the C–C bonds in ethylene oxide (1.472 Å) and ethylenimine (1.480 Å) are unusually short. These facts suggest that ethylene oxide and ethylenimine are tending respectively toward the fragments $H_2C=CH_2 + O$ and NH . It is noteworthy, however, that trimethylene oxide, which cannot so readily "outsert" a group with an open sextet, and yet in which the unshared electrons on oxygen are not fully *trans* to any bonds and so cannot readily participate in intramolecular interactions, forms relatively strong intermolecular bonds. Toward Brønsted acids and the Lewis acid I_2 , the order of basicity of the saturated cyclic ethers is $4 > 5 > 6 > 3$.^{521,522}

4. Structures of Methyl Formate, Cyclic Anhydrides, and Related Molecules

Intramolecular interactions of unshared electrons on ether-like oxygen atoms are particularly pronounced in molecules of simple esters such as methyl formate. The methyl formate molecule is planar except for two of its hydrogen atoms³⁷² (Figure 84). Significantly, the methyl group is *cis* to the carbonyl oxygen atom.³⁷² This configuration places the lone pairs on the ether oxygen atom *trans* to the electron pairs of the carbon-oxygen double bond, when the latter is viewed in its bent-bond representation. A relatively strong intramolecular interaction between the "unshared" electrons on the ether oxygen atom and the pockets off the backsides of the equivalent orbitals of the carbon-oxygen double bond is further indicated by the

(521) M. Tamres and S. Searles, Jr., *J. Phys. Chem.*, **66**, 1099 (1962).

(522) M. Tamres, S. Searles, Jr., and G. M. Goodenow, *J. Am. Chem. Soc.*, **86**, 3934 (1964).

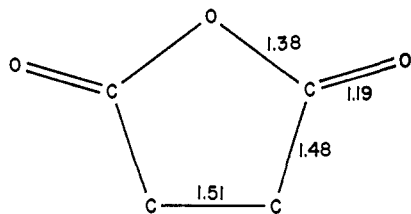

Figure 85.—Structure of maleic anhydride in the solid phase.

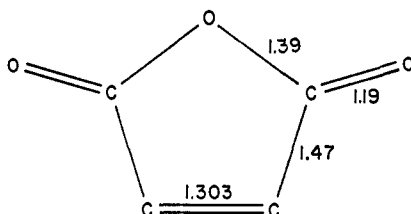

Figure 86.—Structure of succinic anhydride in the solid phase.

relatively short C(carbonyl)-O(methoxy) bond (1.334 ± 0.01 Å) and by the relatively long C(methyl)-O(methoxy) bond (1.437 ± 0.01 Å, compared with 1.428 Å in methyl alcohol and 1.410 Å in dimethyl ether).

The methyl formate configuration has been observed in other esters, *e.g.*, *p*-bromocinnamate,⁵²³ in peroxyperargonic acid,⁵²⁴ $\text{CH}_3(\text{CH}_2)_7\text{COOOH}$, whose CCOOO group is planar, with the last oxygen atom *cis* to the carbonyl oxygen atom, and in two molecules isoelectronic with methyl formate, methyl vinyl ether,⁵²⁵ and propionaldehyde.⁵²⁶

It is noteworthy that a C(carbonyl)-O(ether-like) carbon-oxygen bond appears to be significantly longer than the 1.334 Å observed in methyl formate when the lone pairs on the oxygen are not *trans* to the electron pairs of the carbon-oxygen double bond. Such is the case, for example, in maleic anhydride⁵²⁷ (Figure 85) and succinic anhydride⁵²⁸ (Figure 86). On the other hand, in furan,⁵²⁹ where the lone pairs on the oxygen atom are *trans* to the electron pairs of an adjacent double bond, the C-O bond is, again, relatively short (Figure 87).

Anomalous from the viewpoint of the discussion in this section are the relatively short C-O bonds in ethylene carbonate⁵³⁰ and the equilibrium *trans* configurations reported for nitrous acid⁵³¹ and a number of other compounds of the type $=\text{NOR}$.

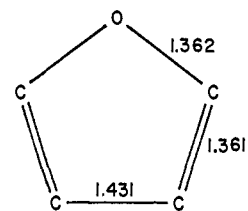

Figure 87.—Structure of furan in the gas phase.

IV. SUMMARY

It is remarkable how far modern structural data support Lewis's view that an understanding of chemical affinity must be sought in the localization of charges,⁵³² and how well that localization of charges is described by the graphic formulas of classical structural theory. The saturation and directional properties of relatively strong inter- and intramolecular interactions now appear as an obvious, if not fully anticipated, consequence of the tetrahedral distribution of charge about combined atoms.

Chemically combined atoms do not behave in their interactions with neighboring charge distributions as simple van der Waals spheres sliced off on those sides where they bond to other atoms. In inter- and intramolecular interactions, atoms appear to behave more like dimpled spheres, with bumps in their valence shells where there are unshared electrons, protonated electrons, and other shared electrons and, between these bumps, hollows, at the faces of the coordinated valence-shell electron polyhedra.

Nature's task, at low temperatures, is how best to fit nucleophilic bumps into electrophilic hollows. In condensed phases, molecules probably use, if only weakly, most of their donor and acceptor sites in some form of inter- and intramolecular interactions, minimizing thereby the energy of the electrostatic fields of their stray feeler lines of force.

Neutralization of charge in molecules whose classical octet structures contain formal charges appears to "over-crowd" atoms whose formal charges are positive.

Intramolecular neutralization of charge seems often to occur through the rotation and tilting of spin sets in such a way that unshared electrons approach electrophilic centers, forming thereby "intramolecular donor-acceptor complexes." Intermolecular charge neutralization occurs through the translation of spin sets toward each other, forming thereby intermolecular donor-acceptor complexes. In both inter- and intramolecular donor-acceptor interactions, the "bond"-shortening effect of unshared electrons and

(523) L. Leiserowitz and G. M. Schmidt, *Acta Cryst.*, **18**, 1058 (1965).

(524) D. Belitskus and G. A. Jeffrey, *ibid.*, **18**, 458 (1965).

(525) N. L. Owen and N. Sheppard, *Proc. Chem. Soc.*, 264 (1963); see also P. Cahill, L. P. Gold, and N. L. Owen, *J. Chem. Phys.*, **48**, 1620 (1968).

(526) S. S. Butcher and E. B. Wilson, Jr., *ibid.*, **40**, 1671 (1964).

(527) R. E. Marsh, E. Ubell, and H. E. Wilcox, *Acta Cryst.*, **15**, 35 (1962).

(528) M. Ehrenberg, *ibid.*, **19**, 698 (1965).

(529) B. Bak, D. Christensen, W. B. Dixon, L. Hansen-Nygaard, J. R. Andersen, and M. Schöttlander, *J. Mol. Spectry.*, **9**, 124 (1962).

(530) C. J. Brown, *Acta Cryst.*, **7**, 92 (1954).

(531) A. P. Cox and R. L. Kuczowski, *J. Am. Chem. Soc.*, **88**, 5071 (1966).

(532) G. N. Lewis, "Valence and the Structure of Atoms and Molecules," The Chemical Catalogue Co., Inc., 1923; reprinted by Dover Publications, Inc., New York, N. Y., 1966.

decrease from "normal" in the donor-acceptor distance $D \cdots A$ (Figure 38) or $B-C$ (18a) is generally much greater than the corresponding bond-lengthening effect and increase from normal in the acceptor-acceptor substituent distance $A-S$ (Figure 38) or $A-B$ (18a).

The chemistry of donor-acceptor interactions is primarily the chemistry of unshared electrons. The mysterious "period" separating the components of molecular compounds, that "full stop to thought" as Remsen called it,⁵³³ represents in many instances a pair of electrons shared unequally by two atoms. Usually, in the union of residual affinities, an unshared pair in the primary shell of a donor atom penetrates only so far as the secondary valence shell of the acceptor atom.

Creation of a secondary coordination shell of electrons about the atomic core of an acceptor atom through formation of "pair-pocket" or "face-centered" bonds

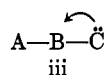

may be compared with the creation of a secondary coordination shell of anions about an ordinary cation—merely a large atomic core—through capping of the faces of the primary polyhedron of anions about the cation by additional anions, as illustrated with the bithiourea-zinc acetate complex⁵³⁴ in Figure 88. Oxygen atoms O(2) and O(4) in Figure 88 belong to the second coordination sphere of Zn; they lie on the O(1)-O(3)S(2) and O(3)S(1)O(1) faces of the coordinated tetrahedron. Sulfur atom S(1), for example, corresponds to the leaving group A in an intramolecular interaction of the type iii above, zinc to the acceptor atom B, oxygen O(3) to the electron pair of the B-C bond, carbon atom C(4) to the donor atom C, and oxygen atom O(4) to the unshared pair on the donor atom.

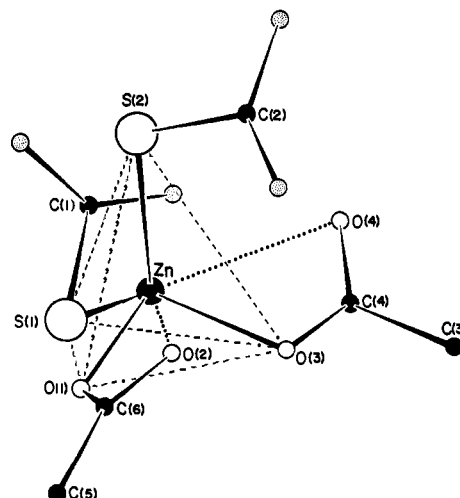

Figure 88.—Structure of the bithiourea-zinc acetate complex.

Face-centered bonds represent transitional interatomic interactions. They are models of interactions that fall between normal van der Waals contacts and single bonds, for which a representation by dashed lines seems appropriate, and interactions that fall between single and double bonds, or double and triple bonds, for which conventional valence strokes augmented by curly arrows (or barbs) have been used.

"A curly arrow," it has been said, "never hit the mark." Yet it is a useful, if still provisional, supplement to the valence stroke, which, alone, cannot indicate the nuances of static, even less dynamic, interatomic interactions. No better method has been found, nor perhaps is required, for representing graphically a smooth transition from weak, secondary donor-acceptor interactions to strong, primary chemical bonds.

ACKNOWLEDGMENTS.—The preparation of this review has been supported by a grant from the National Science Foundation, for which the author is grateful.

(533) G. B. Kauffman, *Educ. Chem.*, 4, 11 (1967).

(534) L. Cavalca, G. F. Gasparri, G. D. Andreotti, and P. Domiano, *Acta Cryst.*, 22, 90 (1967).